

Demco manufacturing
Dethmers Manufacturing Company

Quick Tach

Side Mount Tank Units

FOR MECHANICAL FRONT WHEEL DRIVE TRACTORS

JOHN DEERE 50, 55, & 60 SERIES
JOHN DEERE 7000 SERIES
JOHN DEERE 8000 SERIES
CASE/IH MAGNUM 71, 72, & 89 SERIES
MASSEY FERGUSON 3600 SERIES
FORD TW25, TW35, 8730, & 8830 SERIES
FORD GENESIS (W/ SMART STEER)
8670, 8770, 8870, & 8970
DEUTZ-ALLIS 9170, & 9190
WHITE 170, & 190



ASSEMBLY
CALIBRATION
OPERATION
REPLACEMENT PARTS

READ complete manual CAREFULLY
BEFORE attempting operation.

Doing Our Best To Provide You The Best

MANUAL
OPERATORS

Thank you for purchasing a Demco "Quick Tach" side mounts. We feel you have made a wise choice and hope you are completely satisfied with your "Quick Tach" side mounts. If you have any questions regarding the applications of certain solutions or chemicals, contact your chemical supplier and follow chemical manufacturer recommendations as well as all licensing and use restrictions or regulations.



WARNING: TO AVOID PERSONAL INJURY OR PROPERTY DAMAGE, OBSERVE FOLLOWING INSTRUCTIONS:

Chemicals are dangerous. Know exactly what you're going to do and what is going to happen before attempting to work with these products. Improper selection or use can injure people, animals, plants and soil.

Always wear protective clothing such as coveralls, goggles and gloves when working with chemicals or sprayer.

Be sure to dispose of all unused chemicals or solutions in a proper and ecologically sound manner.

GENERAL INFORMATION

1. Unless otherwise specified, high-strength (grade5) (3 radial-line head markings) hex head bolts are used throughout assembly of this sprayer.
2. Whenever terms "**LEFT**" and "**RIGHT**" are used in this manual it means from a position behind tractor and facing forward.
3. When placing a parts order, refer to this manual for proper part numbers and place order by **PART NO.** and **DESCRIPTION.**

Table of Contents

General information/Bolt Torque	2
Warranty Registration	3-4
Safety Instructions	5-9
Bolt Torque	10
CASE/IH Magnum 71, 72 & 89 Series Undercarriage Parts List	11
John Deere 8000 Series Undercarriage Parts List	12
John Deere 8000 High Clearance Series Undercarriage Parts List .	13 & 14
John Deere 50, 55 & 60 Series Undercarriage Parts List	15 & 16
John Deere 70 Series Undercarriage Parts List	17 & 18
Massey Ferguson 3600 Series Undercarriage Parts List	19
Ford Genesis (w/Smart Steer) Undercarriage Parts List	20
Mounting the Undercarriage	21
Mounting the Saddles and Tanks	22
Parts Breakdown	23 & 24
Optional Wheels & Jackstand (QTWL)	25
Notes:	26 & 27
Equipment Checklist	28



Warranty Registration

Ag	<input type="radio"/>
RV	<input type="radio"/>
Rental	<input type="radio"/>
Brakes	<input type="radio"/>
Marine	<input type="radio"/>

Dethmers Manufacturing Company
 4010 320th Street • Box 189 • Boyden, Iowa 51234
 Toll Free 800-54DEMCO (800-543-3626) • FAX 800-845-6420
 www.demco-products.com

	Very Satisfied	Satisfied	Dissatisfied	Very Dissatisfied
How satisfied are you with our product?	<input type="radio"/>	<input type="radio"/>	<input type="radio"/>	<input type="radio"/>
How satisfied are you with the dealership/distributor sales staff?	<input type="radio"/>	<input type="radio"/>	<input type="radio"/>	<input type="radio"/>
Dealer/Distributor Name _____ City _____ State _____				
How satisfied are you with the company sales staff?	<input type="radio"/>	<input type="radio"/>	<input type="radio"/>	<input type="radio"/>
How satisfied are you with the delivery?	<input type="radio"/>	<input type="radio"/>	<input type="radio"/>	<input type="radio"/>
Did you have any contact with a Demco Representative? If YES , how satisfied were you?	YES <input type="radio"/>	NO <input type="radio"/>	<input type="radio"/>	<input type="radio"/>
I would recommend this product to my family and friends.	YES	NO		
Would you purchase again from DEMCO?	YES	NO		
Since taking delivery, have you been contacted by the dealer?	YES	NO		
Did you have any problems with this DEMCO product? If YES , are you satisfied with the company's resolution of your problem?	YES <input type="radio"/>	NO <input type="radio"/>	<input type="radio"/>	<input type="radio"/>

Why did you purchase this product? _____

Please list the specific source of information prompting this purchase.

After purchasing this product, do you see any needed product improvement? _____ If yes, what improvement? _____

What other products would you like to see DEMCO offer? _____

Comments _____

Owner's Name: _____ Mailing Address: _____

City: _____ State: _____ Zip Code: _____

Model#: _____

Serial #: _____

Purchase Date: _____

Owner's Signature: _____

Please return to DETHMERS MFG. CO. By FAX or tri-folding this form to the backside, it is pre-addressed.

Postage

*Dethmers Manufacturing Company
4010 320th Street, Box 189
Boyden, Iowa 51234*

SAFETY

TAKE NOTE! THIS SAFETY ALERT SYMBOL FOUND THROUGHOUT THIS MANUAL IS USED TO CALL YOUR ATTENTION TO INSTRUCTIONS INVOLVING YOUR PERSONAL SAFETY AND SAFETY OF OTHERS. FAILURE TO FOLLOW THESE INSTRUCTIONS CAN RESULT IN INJURY OR DEATH.



THIS SYMBOL MEANS

ATTENTION

BECOME ALERT

YOUR SAFETY IS INVOLVED!

SIGNAL WORDS

This manual uses the following signal words-- **DANGER**, **WARNING**, and **CAUTION**-- with safety messages. The appropriate signal word has been selected using the following guidelines.

DANGER:

Indicates an imminently hazardous situation that, if not avoided, will result in death or serious injury. This signal word is to be limited to most extreme situations typically for machine components which, for functional purposes, cannot be guarded.

WARNING:

Indicates a potentially hazardous situation that, if not avoided, could result in death or serious injury, and includes hazards that are exposed when guards are removed. It may also be used to alert against unsafe practices.

CAUTION:

Indicates a potentially hazardous situation that, if not avoided, may result in minor or moderate injury. It may also be used to alert against unsafe practices.

**If you have questions not answered in this manual , require additional copies, or if your manual is damaged, please contact your dealer or Dethmers Mfg. Co., P.O. Box 189, 4010 320th Street, Boyden, IA 51234
PH: (712) 725-2311 Toll Free 1-800-543-3626 Fax (712) 725-2380
<http://www.demco-products.com>**



SAFETY...YOU CAN LIVE WITH IT



EQUIPMENT SAFETY GUIDELINES

Every year many accidents occur which could be avoided by a few seconds of thought and more careful approach to handling equipment. You, the operator, can avoid accidents by observing precautions in this section. To avoid personal injury, study precautions and insist those working with you, or you yourself, follow them.

Keep all shields in place. If shield removal becomes necessary for repairs, replace shield prior to use.

Replace any caution, warning, danger or instruction safety decal that is not readable or is missing.

Do not attempt to operate this sprayer under the influence of alcohol or drugs.

Review safety instructions with all users.

Operator should be a responsible adult. **DO NOT ALLOW PERSONS TO OPERATE OR ASSEMBLE THIS SPRAYER UNTIL THEY HAVE DEVELOPED A THOROUGH UNDERSTANDING OF SAFETY PRECAUTIONS AND HOW IT WORKS.**

To prevent injury or death, use a tractor equipped with a roll over protective system (ROPS). Do not paint over, remove, or deface any safety signs or warning decals on your sprayer. Observe all safety signs and practice instructions on them.

Never exceed limits of sprayer. If its ability to do a job, or to do so safely is in question **DON'T TRY IT.**



LIGHTING AND MARKING

It is the responsibility of operator to know lighting and marking requirements of local highway authorities and to install and maintain equipment to provide compliance with regulations. Add extra lights when transporting at night or during periods of limited visibility.

Lighting kits are available from your dealer or manufacturer.



TIRE SAFETY

- Failure to follow proper procedures when mounting tire on rim can produce an explosion resulting in serious injury or death.
- Do not attempt to mount tire unless you have proper equipment and experience.
- Inflating or servicing tires can be dangerous. Whenever possible, trained personnel should be called to service or mount tires.
- Always order and install tires and wheels with appropriate type and load capacity to meet or exceed anticipated weight to be placed on sprayer.



SAFETY SIGN CARE

- Keep safety signs clean and legible at all times.
- Replace safety signs that are missing or have become illegible.
- Replacement parts that displayed a safety sign should also display current sign.
- Safety signs are available from your distributor, dealer parts department, or manufacturer.



REMEMBER

Your best assurance against accidents is a careful and responsible operator. If there is any portion of this manual or function you do not understand, contact your local authorized dealer or manufacturer.



BEFORE OPERATION:

- Carefully study and understand this manual and the Owner's Manual.
- Do not wear loose-fitting clothing which may catch in moving parts.
- Always wear protective clothing and substantial shoes.
- It is recommended that suitable hearing and eye protection be worn.
- Operator may come in contact with certain materials which may require specific safety equipment relative to handling of such materials. (Examples: extremely dusty, molds, fungus, bulk fertilizers, etc.)
- Keep wheel and lug nuts tightened to specified torque.
- Assure that agricultural implement tires are inflated evenly.
- Give sprayer a visual inspection for any loose bolts, worn parts, or cracked welds, and make necessary repairs. Follow maintenance safety instructions included in this manual.
- Be sure there are no tools lying on or in equipment
- Do not use sprayer until you are sure that area is clear, especially around children and animals.
- Don't hurry learning process or take sprayer for granted. Ease into it and become familiar with your new equipment.
- Practice operation of your sprayer and its attachments. Completely familiarize yourself and other operators with its operation before using.
- Use a tractor equipped with Roll Over Protection System (ROPS) and fasten your seat belt prior to starting engine.
- Manufacturer does not recommend usage of tractor with ROPS removed.
- Move tractor wheels to widest recommended settings to increase stability.
- Do not allow anyone to stand between tongue or hitch and towing unit when backing up to equipment.



DURING OPERATION

- Beware of bystanders, **PARTICULARLY CHILDREN!** Always look around to make sure it is safe to start engine of towing unit or move sprayer. This is particularly important with higher noise levels and quiet cabs, as you may not hear people shouting.
- **NO PASSENGERS ALLOWED-** Do not carry passengers anywhere on or in the tractor or sprayer.
- Keep hands and clothing clear of moving parts.
- Do not clean, lubricate, or adjust your sprayer while it is moving.
- When halting operation, even periodically, set tractor or towing unit brakes, disengage PTO, shut off engine, and **remove ignition key**.
- Be especially observant of operating area and terrain- watch for holes, rocks, or other hidden hazards. Always inspect area prior to operation.
 - DO NOT operate near edge of drop-offs or banks.
 - DO NOT operate on steep slopes as overturn may result.
 - Operate up and down (not across) intermediate slopes. Avoid sudden starts and stops.
- Pick the most level possible route when transporting across fields. Avoid edges of ditches, gullies, and steep hillsides.
- Be extra careful when working on inclines.

- Periodically clear equipment of brush, twigs, or other materials to prevent buildup of dry combustible materials.
- Maneuver tractor or towing unit at safe speeds.
- Avoid overhead wires or other obstacles. Contact with overhead lines could cause serious injury or death.
- Avoid loose gravel, rocks, and holes; they can be dangerous for equipment operation or movement.
- Allow for sprayer length when making turns.
- Do not walk or work under raised components or attachments unless securely positioned and blocked.
- Keep all bystanders, pets, and livestock clear of work area.
- Operate towing unit from operators seat only.
- Never stand alongside of unit with engine running or attempt to start engine and/or operate machine while standing alongside of unit.
- Never leave running equipment attachments unattended.
- As a precaution, always recheck hardware on equipment following every 100 hours of operation. Correct all problems. Follow maintenance safety procedures.



FOLLOWING OPERATION

- Following operation, or when unhitching, stop tractor or towing unit, set brakes, disengage PTO and all power drives, shut off engine and **remove ignition key**.
- Store sprayer in an area away from human activity.
- Do not park sprayer where it will be exposed to livestock for long periods of time. Damage and livestock injury could result.
- Do not permit children to play on or around the stored sprayer.
- Make sure all parked machines are on a hard, level surface and engage all safety devices.
- Wheel chocks may be needed to prevent unit from rolling.



HIGHWAY AND TRANSPORT OPERATIONS

- **SAFETY CHAINS:** If equipment is going to be transported on a public highway, always follow state and local regulations regarding safety chains and auxiliary lighting. Be sure to check with local law enforcement agencies for your own particular regulations. If required safety chains should be obtained and installed. Only safety chains (not elastic or nylon/plastic tow straps) should be used to retain connection between towing and towed machines in event of separation of primary attaching system. Use a high strength, appropriately sized hitch pin with a mechanical retainer and attach safety chains. Criss cross chains under tongue and secure to draw bar cage, mounting loops, or bumper frame.
- Adopt safe driving practices:
 - Keep brake pedals latched together at all times. **NEVER USE INDEPENDENT BRAKING WITH SPRAYER IN TOW. LOSS OF CONTROL OR UPSET MAY RESULT.**
 - Always drive at a safe speed relative to local conditions and ensure that your speed is low enough for an emergency stop. Keep speed to a minimum.
 - Reduce speed prior to turns to avoid risk of overturning.
 - Always keep tractor or towing unit in gear to provide engine braking when going downhill. Do not coast.
 - Do not drink and drive!
- Comply with state and local laws governing highway safety and movement of farm machinery on public roads.

- Use approved accessory lighting flags and necessary warning devices to protect operators of other vehicles on highway during transport. Various safety lights and devices are available from your dealer.
- Use of flashing amber lights is acceptable in most localities. However, some localities prohibit their use. Local laws should be checked for all highway lighting and marking requirements.
- When driving tractor and sprayer under 20 mph (40 kph) day or night, use flashing amber warning lights and a slow moving vehicle (SMV) identification emblem.
- Plan your route to avoid heavy traffic.
- Be a safe and courteous driver. Always yield to oncoming traffic in all situations, including narrow bridges, intersections, etc.
- Be observant of bridge load ratings. Do not cross bridges rated lower than gross weight of unit you are operating.
- Watch for obstructions overhead and side to side while transporting.
- Always operate equipment in a position to provide maximum visibility at all times. Make allowances for increased length and weight of sprayer when making turns, or stopping.



PERFORMING MAINTENANCE

- Good maintenance is your responsibility. Poor maintenance is an invitation to trouble.
- Make sure there is plenty of ventilation. Never operate engine of towing vehicle in a closed building. Exhaust fumes may cause asphyxiation.
- Before working on this machine, stop towing vehicle, set brakes, disengage PTO and all power drives, shut off engine and **remove ignition key**.
- Be certain all moving parts and attachments have come to a complete stop before attempting to perform maintenance.
- Always use a safety support and block wheels. Never use a jack to support machine.
- Always use proper tools or equipment for job at hand.
- Use extreme caution when making adjustments.
- Follow torque chart in owners manual when tightening bolts and nuts.
- Never use your hands to locate a hydraulic leak on attachments. Use a small piece of cardboard or wood. Hydraulic fluid escaping under pressure can penetrate skin.
- Openings in skin and minor cuts are susceptible to infection from hydraulic fluid. **Without immediate medical treatment, serious infection and reactions can occur.**
- When disconnecting hydraulic lines, shut off hydraulic supply and relieve all hydraulic pressure.
- Replace **all shields and guards** after servicing and before moving.
- After servicing, be sure all tools, parts and service equipment are removed.
- Do not allow grease or oil to build up on any steps or platform.
- When replacing bolts refer to owners manual.
- Refer to bolt torque chart in owners manual for head identification marking.
- Where replacement parts are necessary for periodic maintenance and servicing, genuine factory replacement parts must be used to restore your equipment to original specifications. Manufacturer will not claim responsibility for use of unapproved parts or accessories and other damages as a result of their use.
- If equipment has been altered in any way from original design, manufacturer does not accept any liability for injury or warranty.
- A fire extinguisher and first aid kit should be kept readily accessible while performing maintenance on this equipment

BOLT TORQUE

TORQUE DATA FOR STANDARD NUTS, BOLTS, AND CAPSCREWS.

Tighten all bolts to torques specified in chart unless otherwise noted. Check tightness of bolts periodically, using bolt chart as guide. Replace hardware with same grade bolt.

NOTE: Unless otherwise specified, high-strength Grade 5 hex bolts are used throughout assembly of equipment.



Torque Specifications

Bolt Torque for Standard bolts *

"A"	GRADE 2		GRADE 5		GRADE 8	
	lb-ft	(N.m)	lb-ft	(N.m)	lb-ft	(N.m)
1/4"	6	(8)	9	(12)	12	(16)
5/16"	10	(13)	18	(25)	25	(35)
3/8"	20	(27)	30	(40)	45	(60)
7/16"	30	(40)	50	(70)	80	(110)
1/2"	45	(60)	75	(100)	115	(155)
9/16"	70	(95)	115	(155)	165	(220)
5/8"	95	(130)	150	(200)	225	(300)
3/4"	165	(225)	290	(390)	400	(540)
7/8"	170	(230)	420	(570)	650	(880)
1"	225	(300)	630	(850)	970	(1310)

Bolt Torque for Metric bolts *

"A"	CLASS 8.8		CLASS 9.8		CLASS 10.9	
	lb-ft	(N.m)	lb-ft	(N.m)	lb-ft	(N.m)
6	9	(13)	10	(14)	13	(17)
7	15	(21)	18	(24)	21	(29)
8	23	(31)	25	(34)	31	(42)
10	45	(61)	50	(68)	61	(83)
12	78	(106)	88	(118)	106	(144)
14	125	(169)	140	(189)	170	(230)
16	194	(263)	216	(293)	263	(357)
18	268	(363)	--	--	364	(493)
20	378	(513)	--	--	515	(689)
22	516	(699)	--	--	702	(952)
24	654	(886)	--	--	890	(1206)

Torque figures indicated are valid for non-greased or non-oiled threads and heads unless otherwise specified. Therefore, do not grease or oil bolts or capscrews unless otherwise specified in this manual. When using locking elements, increase torque values by 5%.

*GRADE or CLASS value for bolts and capscrews are identified by their head markings.

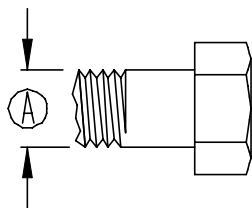

GRADE-2

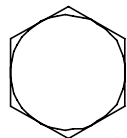

GRADE-5

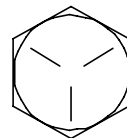

GRADE-8

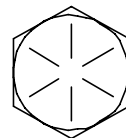

CLASS 8.8



CLASS 9.8



CLASS 10.9



"QUICK-TACH" MFD MOUNTING BRACKETS CASE/IH MAGNUM 7100, 7200 AND 8900 SERIES

These brackets will fit the following tractor models:
7110, 7120, 7130, 7140, 7150, 7210, 7220, 7230,
7240, 7250, 8940, 8950, 8910, 8920, 8930

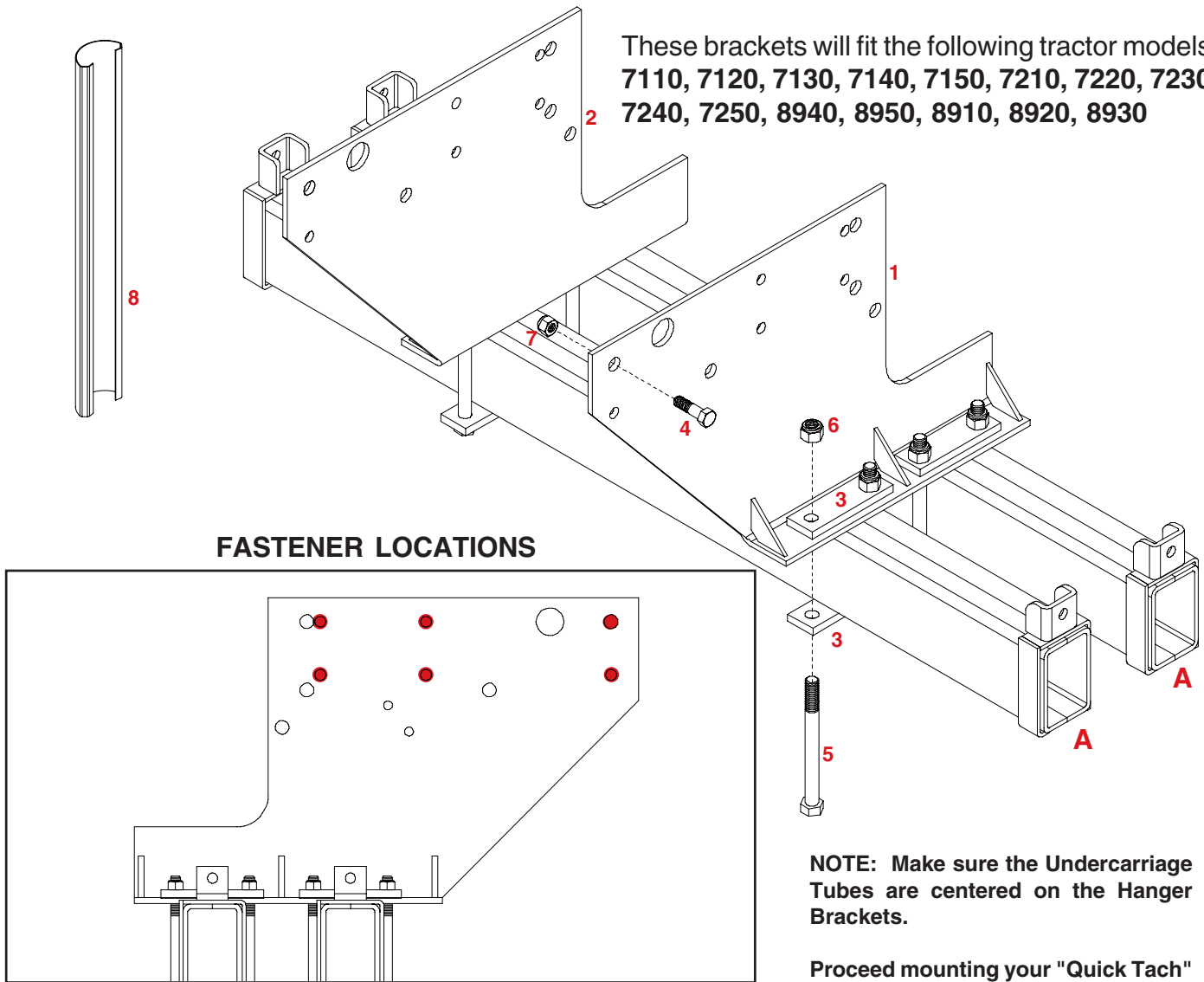

FASTENER LOCATIONS

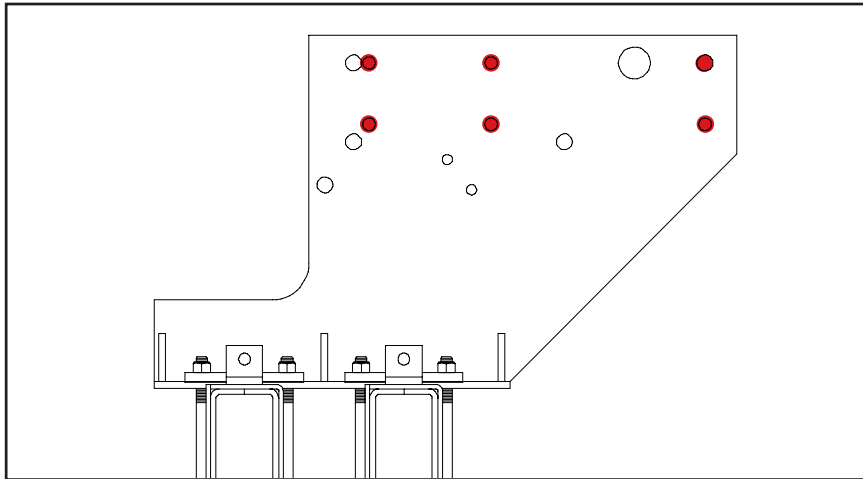

NOTE: Make sure the Undercarriage Tubes are centered on the Hanger Brackets.

Proceed mounting your "Quick Tach" Side Mount Tanks using the assembly instructions in the back of this manual.

ASSEMBLY INSTRUCTIONS

- Begin by bolting the Left (#1) and Right (#2) Hanger Brackets to the tractor frame (**as shown above**) using twelve 5/8" x 5" hex head bolts (#4) and twelve 5/8" nylon insert locknuts (#7).
- Attach the Undercarriage Tubes (**A**) to the Hanger Brackets (#1 & 2) using eight Undercarriage Backup Plates (#3) (**as shown in above drawing**), eight 5/8" x 8" hex head bolts (#5) and eight 5/8" Stover locknuts (#6).

CASE/IH MAGNUM 71 SERIES MOUNTING BRACKETS PARTS LIST

REF. NO.	PART NO.	QTY.	DESCRIPTION
1.	04861-35	1	Left Hanger Bracket
2.	04862-35	1	Right Hanger Bracket
3.	04851-35	8	Undercarriage Backup Plate
4.	01336	12	5/8"-11 UNC x 5" Hex Head Bolt (Gr.5)
5.	03729	8	5/8"-11 UNC x 8" Hex Head Bolt (Gr.5)
6.	03730	8	5/8"-11 UNC Stover Locknut (Gr.B)
7.	02587	12	5/8"-11 UNC Nylon Insert Locknut
8.	04863-37	1	Heat Shield
9.	02175	3	5/8"-11 UNF x 3" Hex Head Bolt (Gr.5)
-	09274-95	4	Spacer Bushing (used on Case IH Model 8950 only.)
-	B128H	2	7" Hose Clamp

Please order replacement parts by PART NO. and DESCRIPTION.

JOHN DEERE 8000 SERIES TRACTORS

NOTE: This undercarriage fits models 8100, 8200, 8300, and 8400.

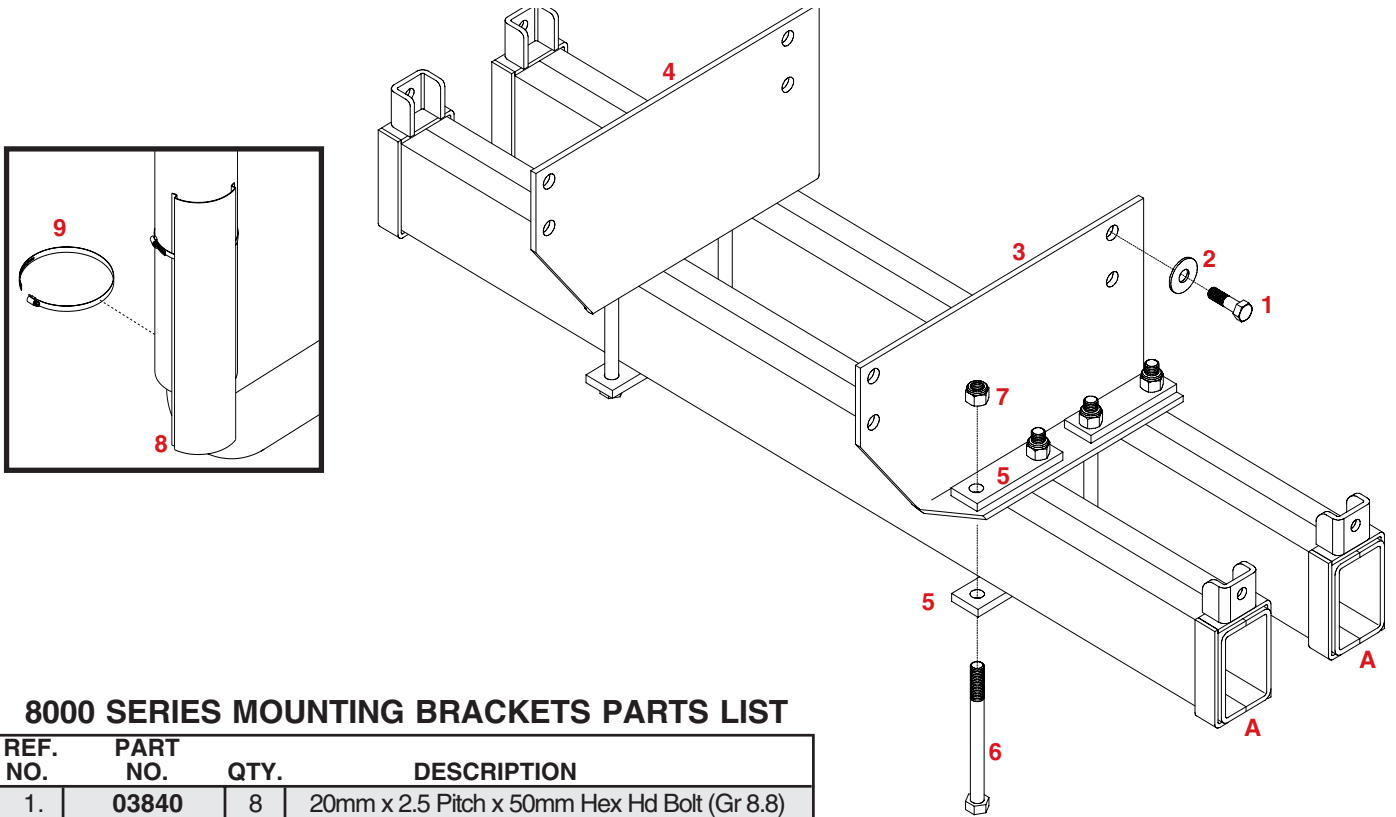

8000 SERIES MOUNTING BRACKETS PARTS LIST

REF. NO.	PART NO.	QTY.	DESCRIPTION
1.	03840	8	20mm x 2.5 Pitch x 50mm Hex Hd Bolt (Gr 8.8)
2.	00492	8	3/4 Flat Washer
3.	03828-35	1	Left Hanger Bracket
4.	03829-35	1	Right Hanger Bracket
5.	04851-35	8	Undercarriage Backup Plate
6.	03729	8	5/8"-11 UNC x 8" Hex Head Bolt (Gr.5)
7.	03730	8	5/8"-11 UNC Stover Locknut (Gr.B)
8.	03839-37	1	Heat Shield
9.	B128H	2	Shield Clamp

Please order replacement parts by **PART NO.** and **DESCRIPTION**.

ASSEMBLY INSTRUCTIONS

1. The front fenders and the tool box **must be** removed.
2. Remove the Left and Right Handrails. **Note: Left and right handrails are determined when entering the tractor.** Loosen the bolts to pivot the steps towards rear of tractor as far as possible. Retighten the step bolts. Reverse the right handrail and remount to the steps (see photo).
3. Mount the left hanger plate (#3) and right hanger plate (#4) using the eight 20mm x 50mm bolts (#1) and eight 3/4" flatwashers (#2). Tractors equipped with radar require one longer bolt.
4. Attach the Undercarriage Tubes (**A**) to the Hanger Brackets using eight Undercarriage Backup Plates (#5), eight 5/8" x 8" hex head bolts (#6) and eight 5/8" stover locknuts (#7).
5. Mount the Heat Shield (#8) as low as possible to muffler using two gear clamps (#9).

CAUTION: MUFFLER MAY BE HOT.



"QUICK-TACH" SIDE MOUNT HIGH CLEARANCE TANK BRACKETS

JOHN DEERE 8000 SERIES TRACTORS

NOTE: This undercarriage fits models 8100, 8200, 8300, and 8400.

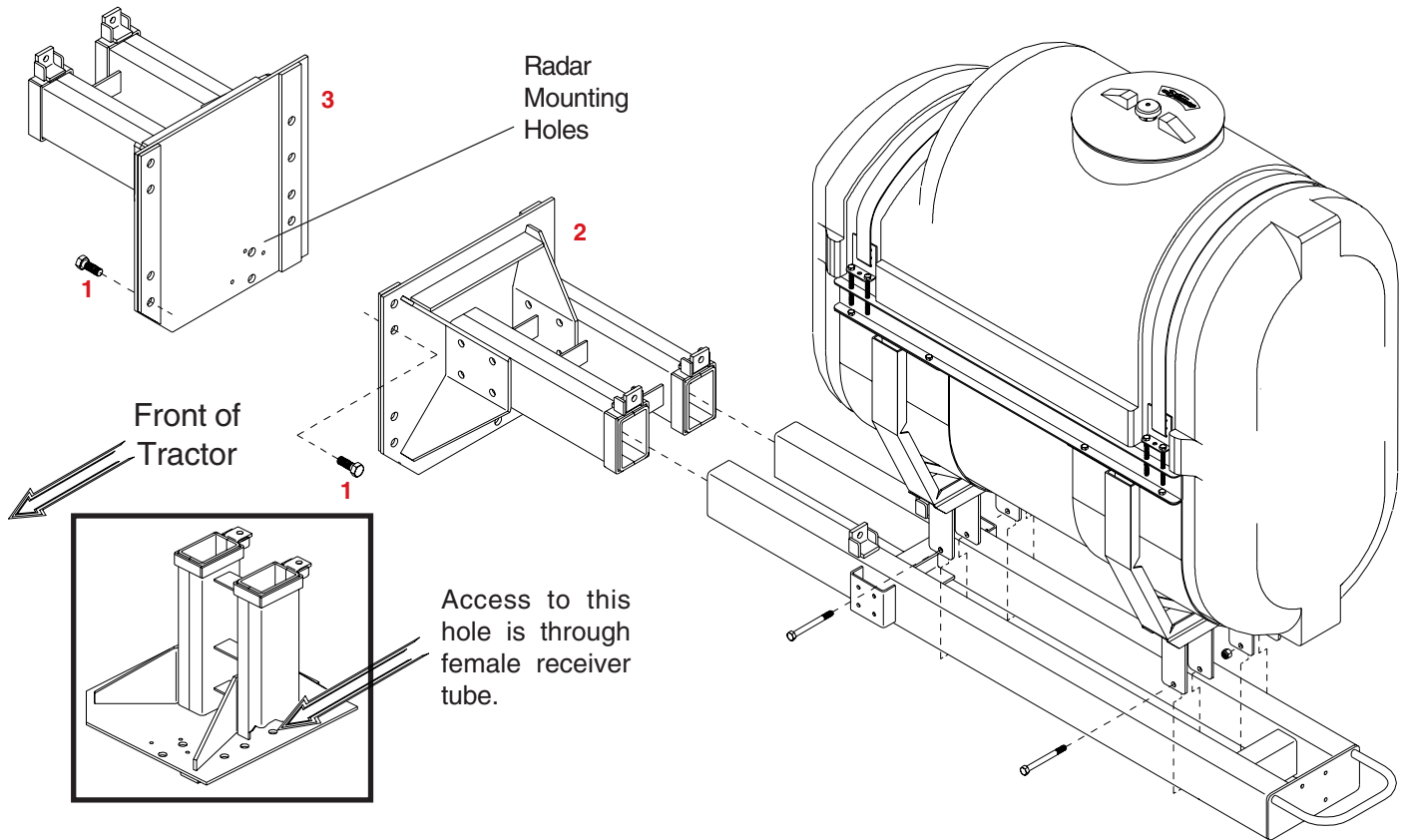

MOUNTING BRACKETS PARTS LIST

REF. NO.	PART NO.	QTY.	DESCRIPTION
1.	03907	16	20mm x 2.5 Pitch x 60mm Hex Hd Bolt (Gr 8.8)
2.	03903	1	Left Hanger Bracket
	03904	1	Right Hanger Bracket

Please order replacement parts by PART NO. and DESCRIPTION.

ASSEMBLY INSTRUCTIONS

1. The tool box and front fenders **must be** removed. If your tractor is equipped with radar, it must be removed and remounted after mounting hanger plates.
2. Remove the Left and Right Handrails. **Note: Left and right handrails are determined when entering the tractor.** Loosen the bolts to pivot the steps towards rear of tractor as far as possible. Retighten the step bolts. Reverse the right handrail and remount to the steps (see photo).
3. Mount the left hanger plate (#2) and right hanger plate (#3) using the sixteen 20mm x 60mm bolts (#1). Note that one bolt must be installed inside rear receiver tube.
4. Remount the radar using the existing metric bolts. Nuts must be purchased from your local hardware store. The large 7/8" diameter holes are for factory radar. The 3/8" holes are for John Deere planter radar

NOTE: Refer to the owners manual for Undercarriage, Tank and Saddle mounting instructions and parts list.



Installing the Heat Shield

Mount the Heat Shield (#1) as low as possible to muffler using two gear clamps (#2).

CAUTION: MUFFLER MAY BE HOT.

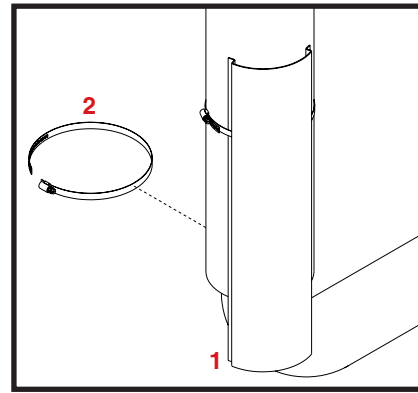

HEAT SHIELD PARTS LIST

REF. NO.	PART NO.	QTY.	DESCRIPTION
1.	03839	1	Heat Shield
2.	B128H	2	Shield Clamp

Please order replacement parts by PART NO. and DESCRIPTION.

Optional Wheel Mounting Angle and Ground Stand for John Deere High Clearance Side Mount Tanks

NOTE: Refer to the owners manual for Wheel and Ground Stand mounting instructions and parts list.

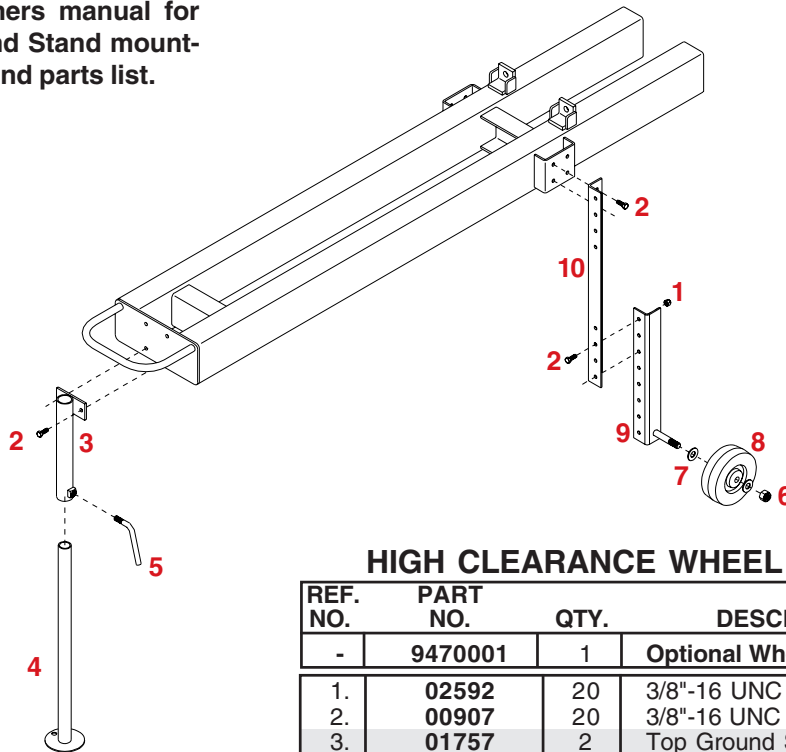

HIGH CLEARANCE WHEEL KIT PARTS LIST

REF. NO.	PART NO.	QTY.	DESCRIPTION
-	9470001	1	Optional Wheels and Jackstand
1.	02592	20	3/8"-16 UNC Nylon Insert Locknut
2.	00907	20	3/8"-16 UNC x 1 Hex Head Bolt (gr. 5)
3.	01757	2	Top Ground Stand
4.	03906	2	24" Long Bottom Ground Stand
5.	00161	2	Lock Handle
6.	02587	4	5/8"-11 UNC Nylon Insert Locknut
7.	01908	8	5/8" x 16 gauge Machine Washer
8.	04445	4	6" x 2" Soft Tread Rubber Wheel
9.	01764	2	Right Lower Axle Bracket (shown)
-	01770	2	Left Lower Axle Bracket (not shown)
10.	03905	4	24" Long Upper Wheel Bracket

Please order replacement parts by PART NO. and DESCRIPTION.

"QUICK-TACH" SIDE MOUNT TANK BRACKETS

JOHN DEERE 50, 55 & 60 SERIES TRACTORS

NOTE: This undercarriage fits models 4450, 4650, 4850, 4555, 4755, 4955, 4560, 4760, and 4960.

NOTE: The four 5/8" x 1-1/2" Hex Head Bolts (#11) and four 5/8" Nylon Insert Locknuts (#18) are used to bolt the Hanger Brackets (#1) to the tractor frame.

NOTE: Make sure the Undercarriage Tubes are centered on the Side Frames.

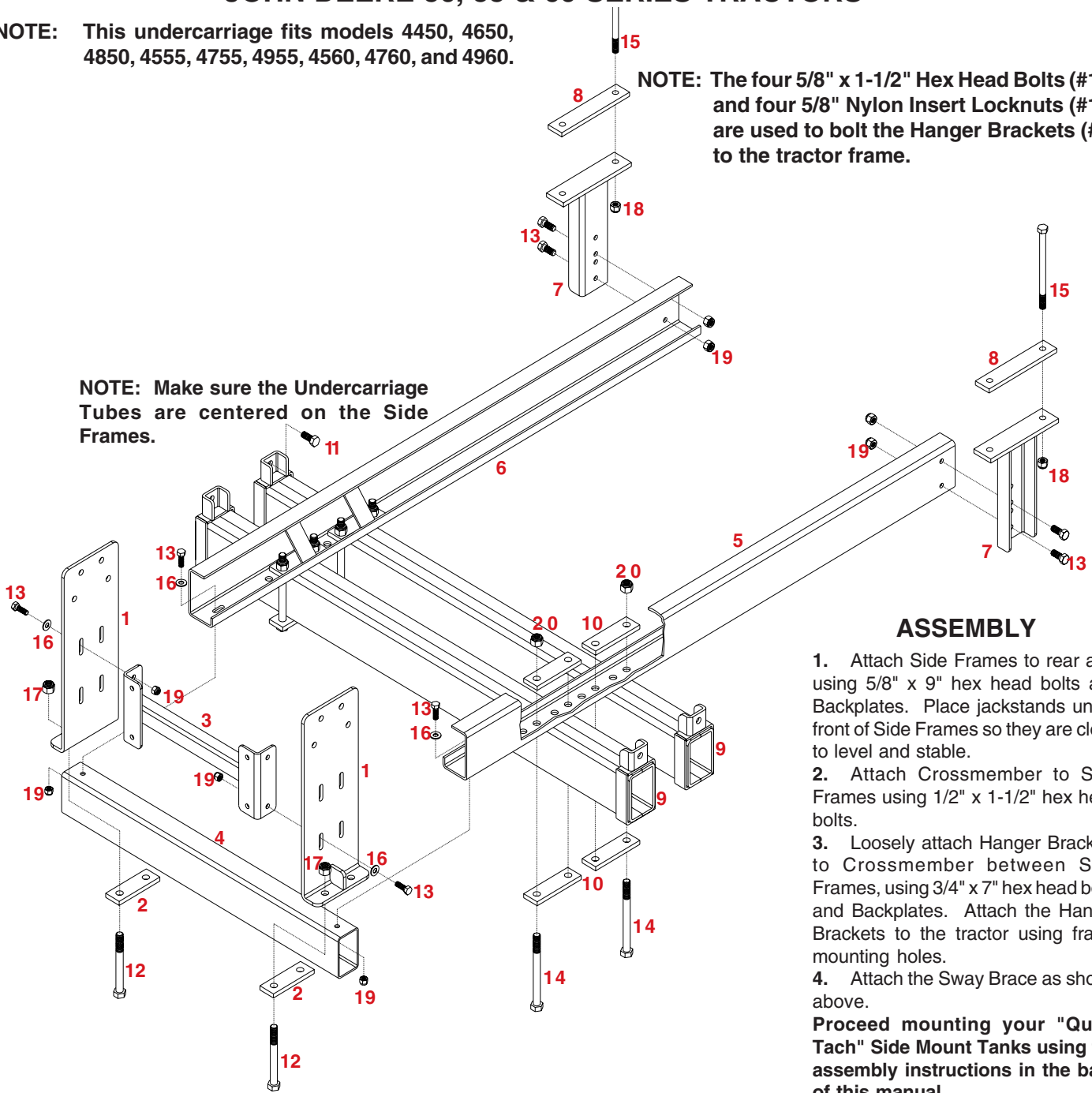

ASSEMBLY

1. Attach Side Frames to rear axle using 5/8" x 9" hex head bolts and Backplates. Place jackstands under front of Side Frames so they are close to level and stable.
2. Attach Crossmember to Side Frames using 1/2" x 1-1/2" hex head bolts.
3. Loosely attach Hanger Brackets to Crossmember between Side Frames, using 3/4" x 7" hex head bolts and Backplates. Attach the Hanger Brackets to the tractor using frame mounting holes.
4. Attach the Sway Brace as shown above.

Proceed mounting your "Quick Tach" Side Mount Tanks using the assembly instructions in the back of this manual.

"QUICK-TACH" SIDE MOUNT UNDERCARRIAGE PARTS LIST FOR JOHN DEERE (MFD)

REF. NO.	PART NO.	QTY.	DESCRIPTION
1.	04865-35	2	Hanger Brackets
2.	04860-35	2	Hanger Bracket Back-up Plates
3.	04853-35	1	Anti-sway Top Crossmember
4.	04857-35	1	Center Bottom Crossmember
5.	04854-35	1	Left Side Frame
6.	04855-35	1	Right Side Frame
7.	04864-35	2	Side Frame Uprights
8.	04856-35	2	Side Frame Back-up Plates
9.	04850-35	2	Quick-Tach Undercarriage Tubes
10.	04851-35	8	Undercarriage Tubes Back-up Plates
11.	04051	4	5/8"-11 UNC x 1-1/2" Hex Head Bolts(Gr.5)
12.	01964	4	3/4"-10 UNC x 7" Hex Head Bolts (Gr.5)
13.	01254	10	1/2"-13 UNC x 1-1/2" Hex Head Bolts(Gr.5)
14.	03729	8	5/8"-10 UNC x 8" Hex Head Bolts (Gr.5)
15.	04835	4	5/8"-11 UNC x 9" Hex Head Bolts (Gr.5)
16.	00085	6	1/2" Flatwashers
17.	02961	4	3/4"-10 UNC Nylon Insert Locknut
18.	02587	4	5/8"-11 UNC Nylon Insert Locknut
19.	02178	10	1/2"-13 UNC Nylon Insert Locknut
20.	03730	8	5/8"-11 UNC Stover Locknut (Gr.B)
-	04226	3	3/8"-16 UNC x 2" Hex Head Bolt
-	02592	3	3/8"-16 UNC Nylon Insert Locknut
-	00059	3	3/8" Flatwasher
-	01253	2	1/2"-13 UNC x 2" Hex Head Bolt

Please order replacement parts by PART NO. and DESCRIPTION.

"GLST" STEP RELOCATION KIT - JD MODELS 50 AND 55 SERIES TRACTORS

RELOCATION INSTRUCTIONS

1. If you have installed the Side Mounts on a Model 50 or 55 Series John Deere, you need to relocate the step.
2. Begin by unbolting the existing steps from the tractor.
3. Attach the Top Step Bracket (#1) to the Hanger Brackets on the left side of tractor using two 1/2" x 2" hex head bolts (#4), 1/2" flatwasher (#5) and 1/2" nylon insert locknuts (#6) in place of the existing 1/2"x1-1/2" bolts that attach the Top Crossmember to the Hanger Brackets.
4. Bolt the Step to the Step Bracket (#1) using a 1/2" x 2" hex head bolt (#4), 1/2" flatwasher (#5) and a 1/2" nylon insert locknut (#6). Also use two 3/8" x 2" hex head bolts (#7), four 3/8" flatwashers (#8) and two 3/8" nylon insert locknuts (#9).
5. Attach the Step Brace (#2) to the Left Side Frame and Crossmember using a 1/2" x 2" hex head bolt (#4), 1/2" flatwasher (#5) and a 1/2" nylon insert locknut (#6) in place of the 1/2" x 1-1/2" hex head bolt, flatwasher and nut that was used to bolt the side Frame to the Bottom Crossmember.
6. Attach the bottom of the steps to the Step Brace using a 3/8" x 2" hex head bolt (#7), 3/8" flatwasher (#8), and 3/8" nylon insert locknut (#9).

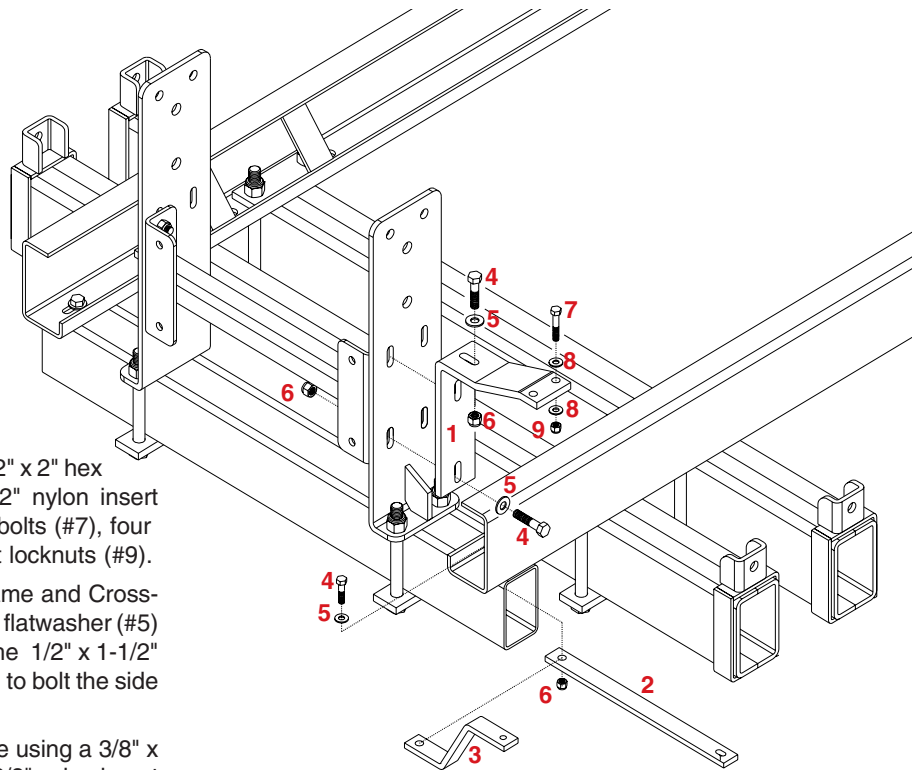

RELOCATED STEP (SHOWN BELOW)

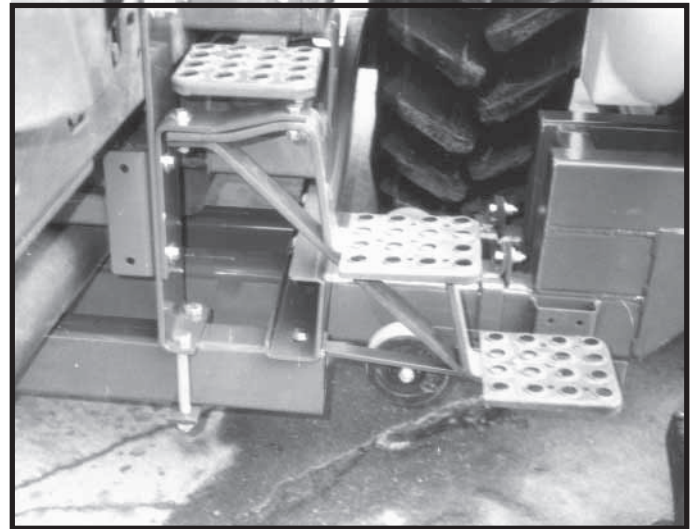

REF. NO.	PART NO.	QTY.	DESCRIPTION
1.	04858-35	1	Top Step Bracket
2.	04859-35	1	Step Brace (55 Series)
3.	04849-35	1	Step Brace (50 Series)
4.	01253	4	1/2"-13 UNC x 2" Hex Head Bolt (Gr.5)
5.	00085	1	1/2" Flatwasher
6.	02178	4	1/2"-13 UNC Nylon Insert Locknut
7.	04226	3	3/8"-16 UNC x 2" Hex Head Bolt (Gr.5)
8.	00059	5	3/8" Flatwasher
9.	02592	3	3/8"-16 UNC Nylon Insert Locknut

1. Disconnect the radar 4-prong plug from under the tractor hood. Remove the radar from the tractors left side (under the step).
2. Remount the radar to the right side with the aid of the bracket and bolts provided.
3. Locate the bracket to the right side of tractor as far back as possible toward the exhaust manifold. Attach to the tractor using two 5/8" x 1-1/2" bolts with flatwasher and nylon insert locknuts.
4. Attach the radar unit to the underside of the bracket with three 1/2" x 1-1/2" bolts with flatwashers and nylon insert locknuts.
5. Re-route the radar wire harness and plug back into the plug under the tractor hood.

PARTS LIST

REF. NO.	PART NO.	QTY.	DESCRIPTION
1.	04832-35	1	Radar Mtg. Bracket
2.	04051	2	5/8"-11UNC x 1-1/2" Bolt (Gr.5)
3.	00477	2	5/8" Flatwasher
4.	02587	2	5/8"-11UNC Nylon Insert Locknut
5.	01254	3	1/2"-13UNC x 1-1/2" Bolt (Gr.5)
6.	00085	3	1/2" Flatwasher
7.	02178	3	1/2"-13UNC Nylon Insert Locknut

RADAR RELOCATION KIT

NOTE: The radar unit may have to be recalibrated, check your tractors owners manual for the proper calibration procedure.



Attach to right side of tractor using 5/8" x 1-1/2" bolts.

Attach radar using 1/2" x 1-1/2" bolts.

"QUICK-TACH" SIDE MOUNT TANK BRACKETS JOHN DEERE 7000 SERIES TRACTORS

NOTE: This undercarriage fits models 7600, 7610, 7700, 7710, 7810, and 7800.
Will not work on 20 series

NOTE: Refer to next page for step relocation mounting instructions.
• Step relocation parts are included.

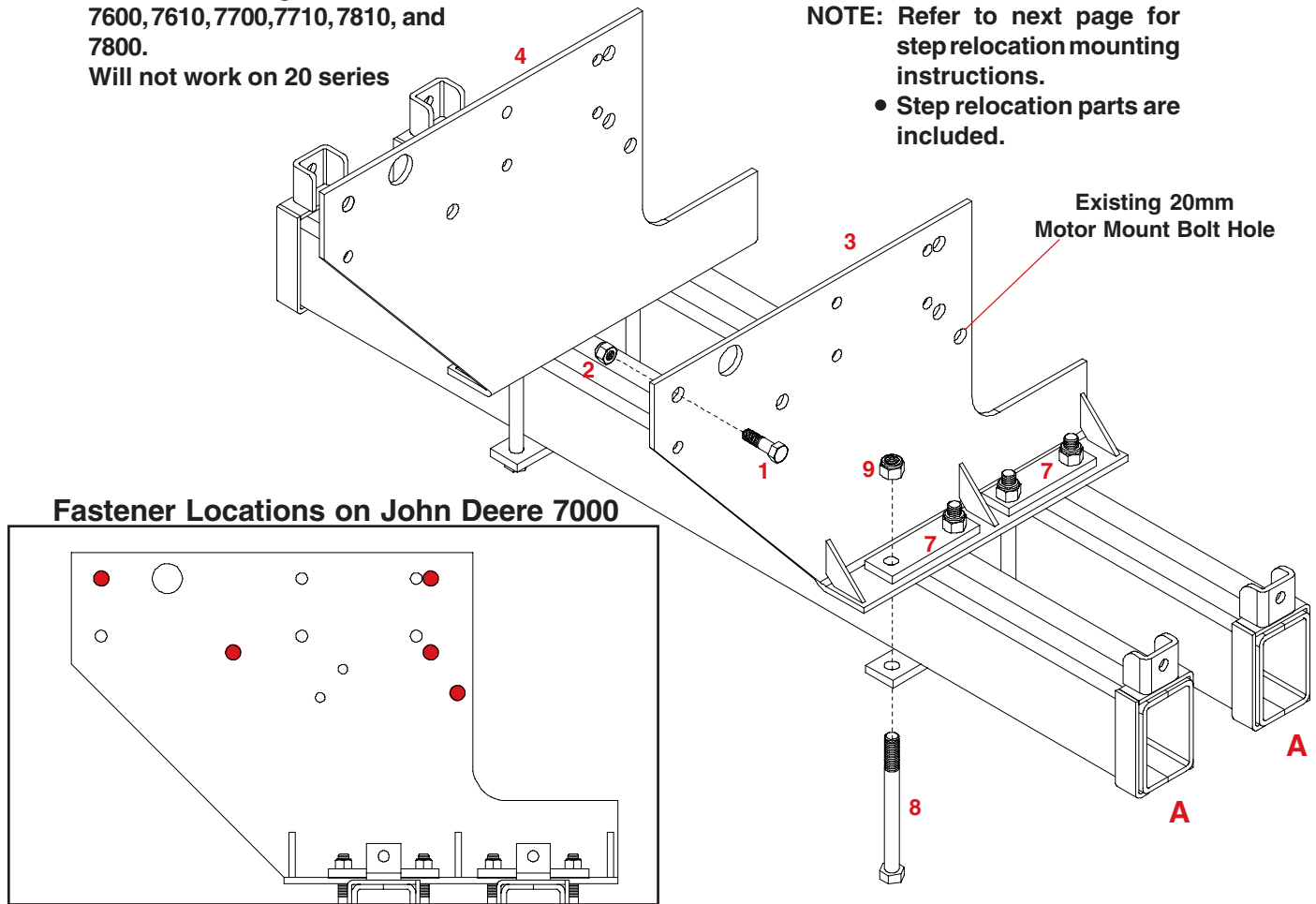

7000 SERIES MOUNTING BRACKETS PARTS LIST

1.	01235	8	3/4"-10 UNC x 2" Hex Head Bolt (Gr.5)
2.	02961	8	3/4"-10 UNC Nylon Insert Locknut
3.	04861-35	1	Left Hanger Bracket
4.	04862-35	1	Right Hanger Bracket
5.	01253	2	1/2"-13 UNC x 2" Hex Head Bolt (Gr.5)
6.	02178	2	1/2" Nylon Insert Locknut
7.	04851-35	8	Undercarriage Backup Plate
8.	03729	8	5/8"-11 UNC x 8" Hex Head Bolt (Gr.5)
9.	03730	8	5/8"-11 UNC Stover Locknut (Gr.B)

Please order replacement parts by **PART NO.** and **DESCRIPTION.**

ASSEMBLY INSTRUCTIONS

- You will have to temporarily take off the tractor's radar. Remove existing bolts and unplug the unit. Set unit off to the side until later when it will be reinstalled, also remove the radar wire from the access hole. Locate the five mounting holes on the frame of the tractor. You will find that the lowest mounting hole is secured with an existing 20 mm motor mount bolt. Remove this bolt, place the side mount hanger bracket (#3 or #4) in place so that all the five holes align, as shown in drawing. Replace the 20 mm motor mount bolt and place four 3/4" x 2" bolts (#1) in the remaining holes and secure with four 3/4" nylon locknuts (#2).
Repeat mounting instructions for the other side.
- Now remount the radar unit in the original location. You will have to reroute radar wire over the top of the frame instead of through the frame access hole. Reinstall the unit with the supplied 1/2" x 2" hex bolts (#5) and nylon locknuts (#6). **NOTE: The radar unit may have to be recalibrated, check your tractor's owner manual for the proper calibration procedure.**
- Attach the Undercarriage Tubes (A) to the Hanger Brackets using eight Undercarriage Backup Plates (#7), eight 5/8" x 8" hex head bolts (#8) and eight 5/8" nylon insert locknuts (#9).

"QUICK-TACH" SIDE MOUNT TANK BRACKETS JOHN DEERE 7000 SERIES TRACTORS

1. You will have to remove the steps from the step/storage box to move them from an angled position to the straight outward position. Place three 1/2" x 2" carriage bolts (#2) through the top of the Step Relocation Plate (#1) for mounting steps later. **NOTE:** On the step relocation plate, the 1/4" spacers face upward and the 1/2" spacers face downward.
2. Proceed by bolting the step relocation plate to the bottom of the step/storage box, where steps used to be, using existing carriage bolts and nuts.
3. Now place the steps in an outward position and fasten them to the relocation plate using three 1/2" nylon insert locknuts (#3).

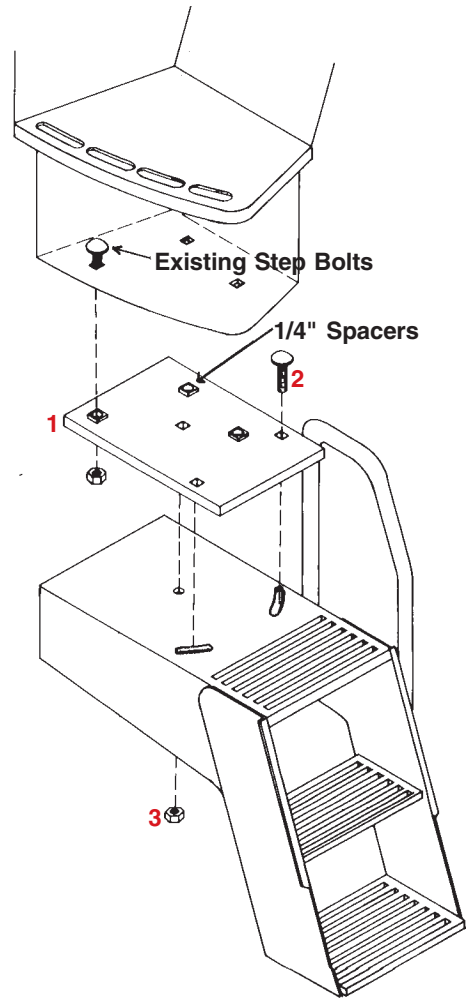

7000 SERIES STEP RELOCATION PARTS LIST

REF. NO.	PART NO.	QTY.	DESCRIPTION
1.	03343-35	1	Step Relocation Plate
2.	03364	3	1/2"-13 UNC x 2" Carriage Bolt (Gr.5)
3.	02178	3	1/2"-13 UNC Nylon Insert Locknut

Please order replacement parts by **PART NO.** and **DESCRIPTION**.

STEP and MOUNTING BRACKET LOCATIONS

NOTE: Make sure the Undercarriage Tubes are centered on the Hanger Brackets.

Proceed mounting your "Quick Tach" Side Mount Tanks using the assembly instructions in the back of this manual.

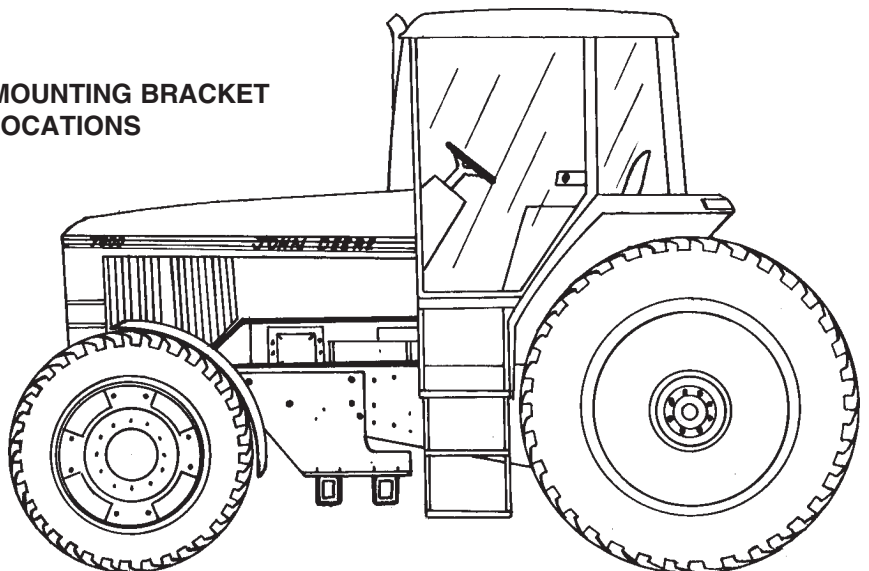

"QUICK TACH" SIDE MOUNT TANK BRACKETS MASSEY FERGUSON 3600 SERIES TRACTORS

Note: These brackets fit tractor models 3630, 3650, 3660, 3670, 3680, 3690
The optional frame mounting plates must be purchased from Massey Ferguson

**FRONT
FENDERS
MUST BE
REMOVED**

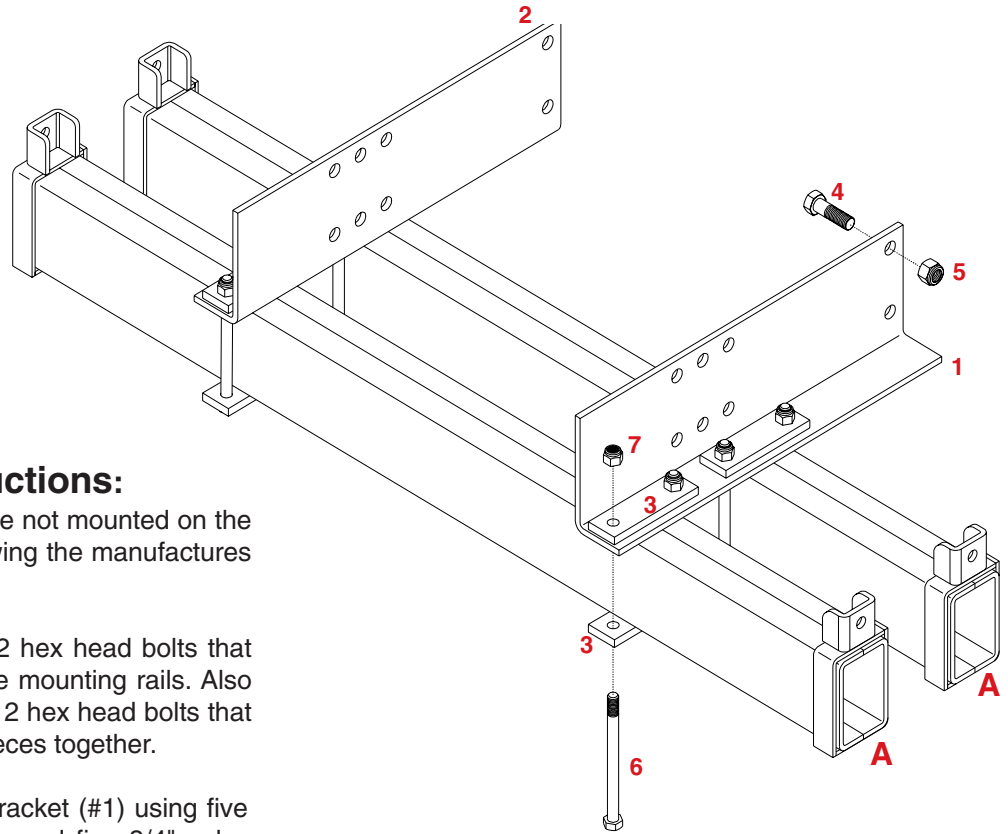

Installation Instructions:

If the tractors frame mounting rails are not mounted on the tractor begin by installing them following the manufactures instructions.

Begin by removing the three 3/4" x 2 hex head bolts that mount the crossmember to the frame mounting rails. Also remove the front two of the six 3/4" x 2 hex head bolts that attach the two frame mounting rail pieces together.

Mount the left side hanger bracket (#1) using five 3/4" x 2-1/2" hex head bolts and five 3/4" nylon insert locknuts. These are replacing the five bolts that were just removed. Use three of the five 3/4" x 2 hex head bolts that were removed in the top three holes above the crossmember mounting holes.

Repeat the above steps for other side.

Mount the undercarriage tubes (A) to the hanger bracket using eight undercarriage backup plates (# 3), eight 5/8" x 8 hex head bolts (# 6) and eight 5/8" stover locknuts (# 7).

NOTE: Make sure the Undercarriage Tubes are centered on the Hanger Brackets.

Proceed mounting your "Quick Tach" Side Mount Tanks using the assembly instructions in the back of this manual.

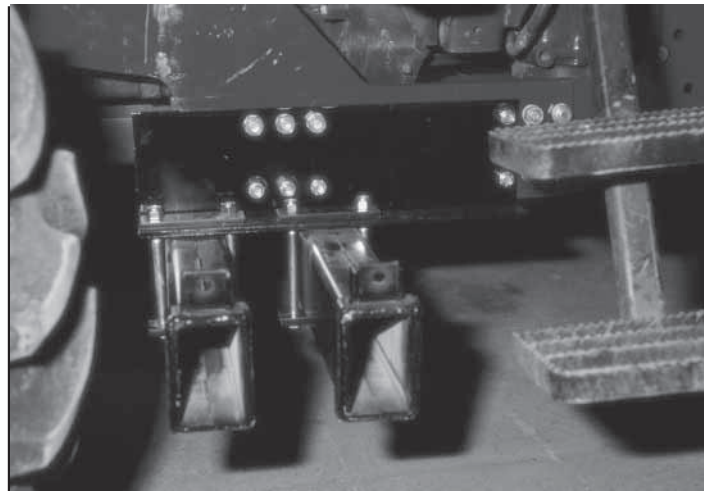

MASSEY FERGUSON MOUNTING BRACKET PARTS LIST

REF. NO.	PART NO.	QTY.	DESCRIPTION
1.	03886-35	1	Left Hanger Bracket
2.	03887-35	1	Right Hanger Bracket
3.	04851-35	8	Undercarriage Backup Plate
4.	05047	16	3/4"-10 UNC x 2-1/2" Hex Head Bolt (Gr.5)
5.	02961	16	3/4"-10 UNC Nylon Insert Locknut
6.	03729	8	5/8"-11 UNC x 8" Hex Head Bolt (Gr.5)
7.	03730	8	5/8"-11 UNC Stover Locknut (Gr.B)

Please order replacement parts by PART NO.and DESCRIPTION.

"QUICK TACH" SIDE MOUNT TANK BRACKETS FORD GENESIS WITH SMART STEER

These brackets will fit
the following tractor models:
8670, 8770, 8870 & 8970
Buhler 2145, 2160, 2189, and 2210

NOTE: Make sure the Undercarriage Tubes are centered on the Hanger Brackets.

88" Row setting with 14.9 x 30 tires will restrict turing radius.

Proceed mounting your "Quick Tach" Side Mount Tanks using the assembly instructions in the back of this manual.

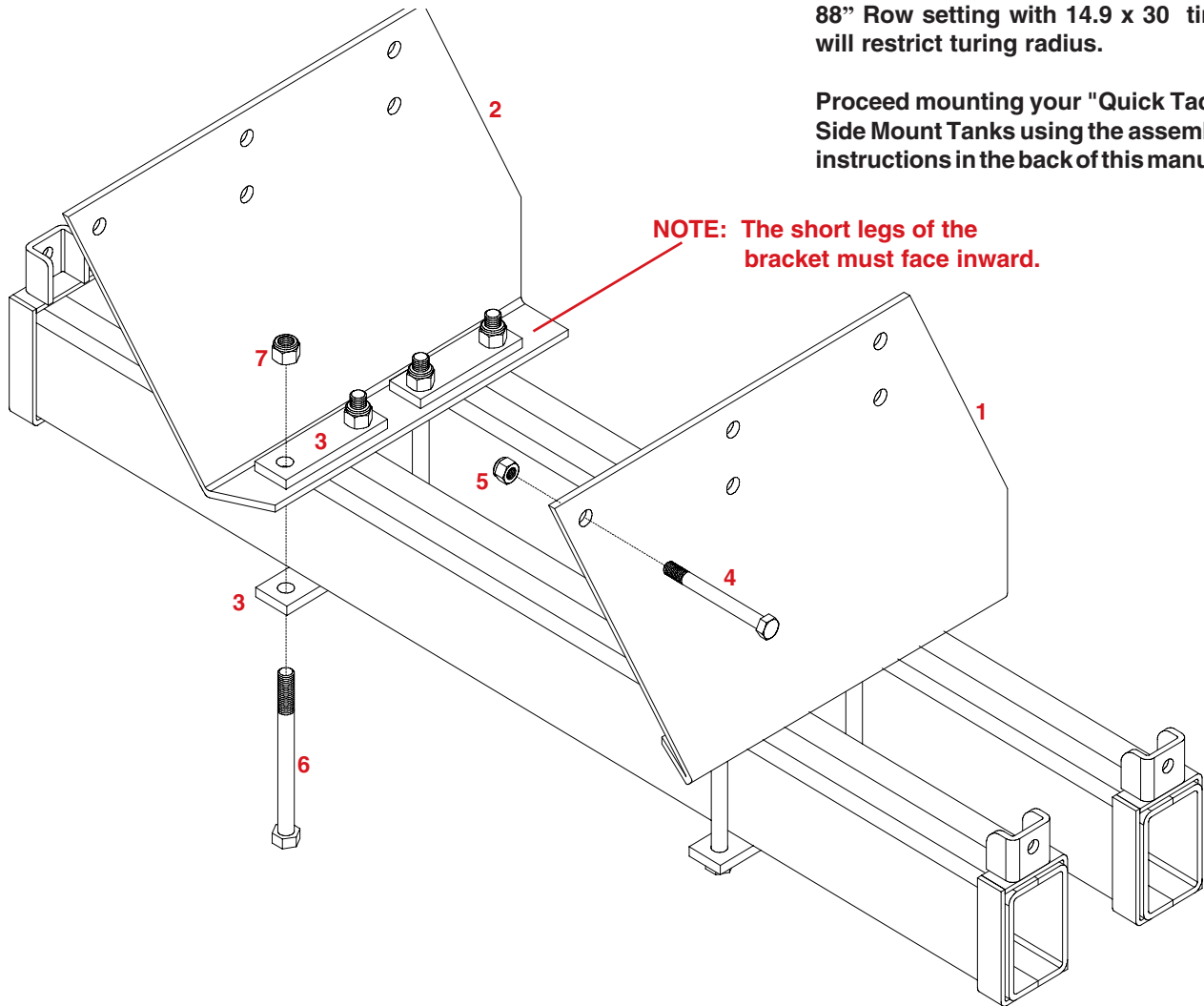

GENESIS MOUNTING BRACKET PARTS LIST

REF. NO.	PART NO.	QTY.	DESCRIPTION
1.	03719-35	1	Left Hanger Bracket
2.	03720-35	1	Right Hanger Bracket
3.	04851-35	8	Undercarriage Backup Plate
4.	02389	10	3/4"-10 UNC x 5" Hex Head Bolt (Gr.5)
5.	02961	10	3/4"-10 UNC Nylon Insert Locknut
6.	03729	8	5/8"-11 UNC x 8" Hex Head Bolt (Gr.5)
7.	03730	8	5/8"-11 UNC Stover Locknut (Gr.B)

Please order replacement parts by PART NO. and DESCRIPTION.

MOUNTING THE UNDERCARRIAGE

3. Slide the two undercarriage tubes (#6) under the tractor, with the welded-on tabs pointing up. Fasten the undercarriage tubes to the mounting brackets. **DO NOT TIGHTEN NUTS ON THE BOLTS.**

4. Slide both main frames (#10) into undercarriage tubes (#6) as shown. Bolt each main frame to its carrier tube using a 5/8"-18UNC x 2" grade 5 bolt (#11), lockwasher and nut through the two welded-on tabs. **Note: Different mounting procedures and parts may be required. Refer to the instruction page for your tractor.** Now tighten the nuts on the bolts holding the carrier tubes (#6) to the mounting brackets.

5. Insert the rubber grommets (#5) around the inside hole of the plate on the inside of the main frames.

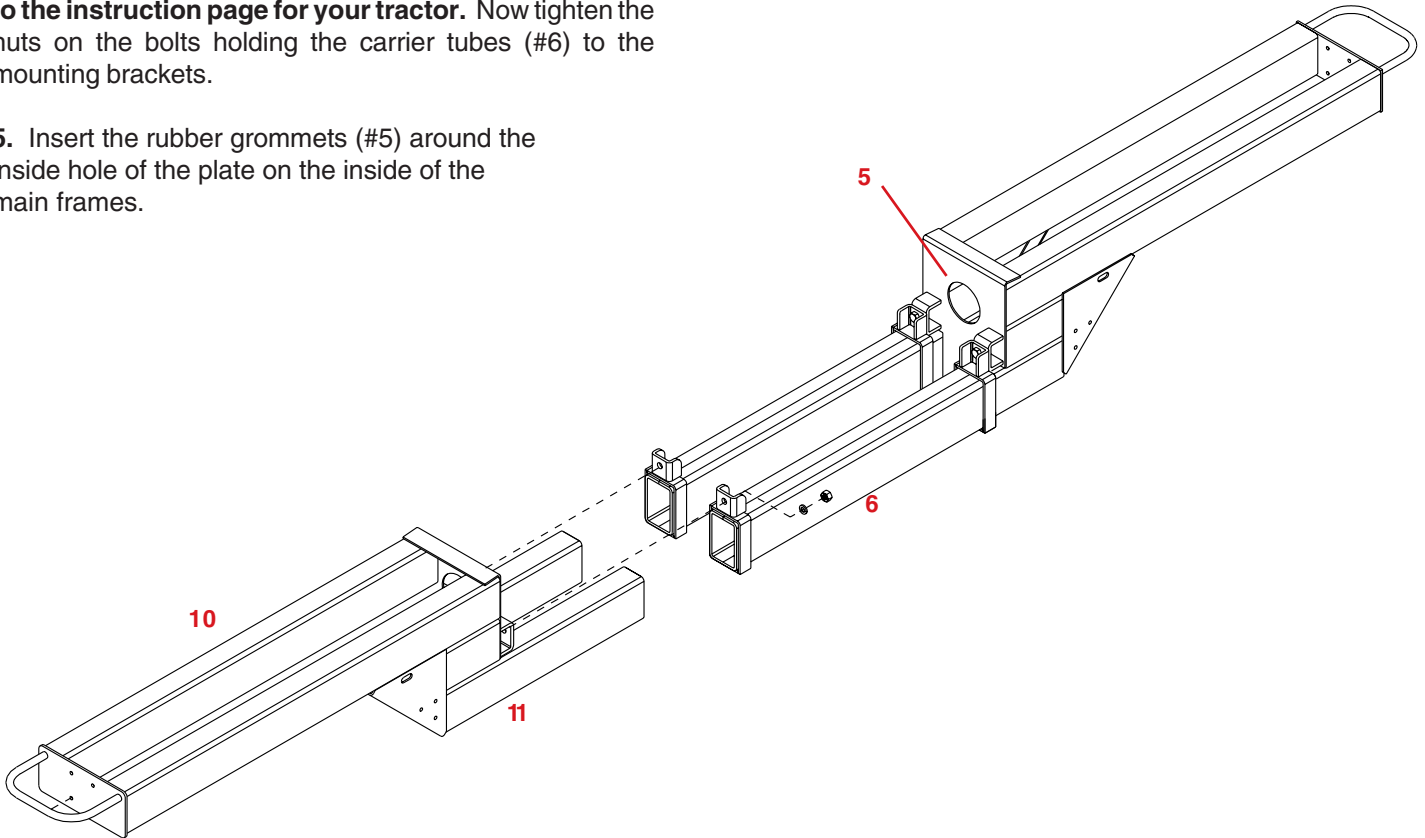

To remove or reinstall the "Quick Tach" Side Mounts

Remove the two 5/8" x 2" bolts (#11) through the angles on the mounting frames. Then pull the main frame out of the undercarriage tubes. If the jack and wheel option is used, put them in the vertical position and pull the main frame out and roll the unit away.

The tanks must be completely empty before they can be removed.

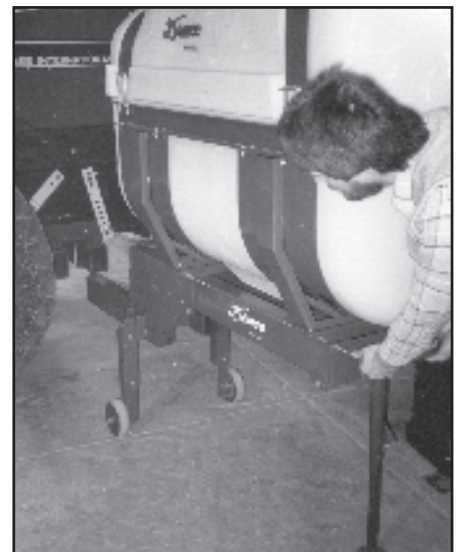

MOUNTING THE SADDLES AND TANKS

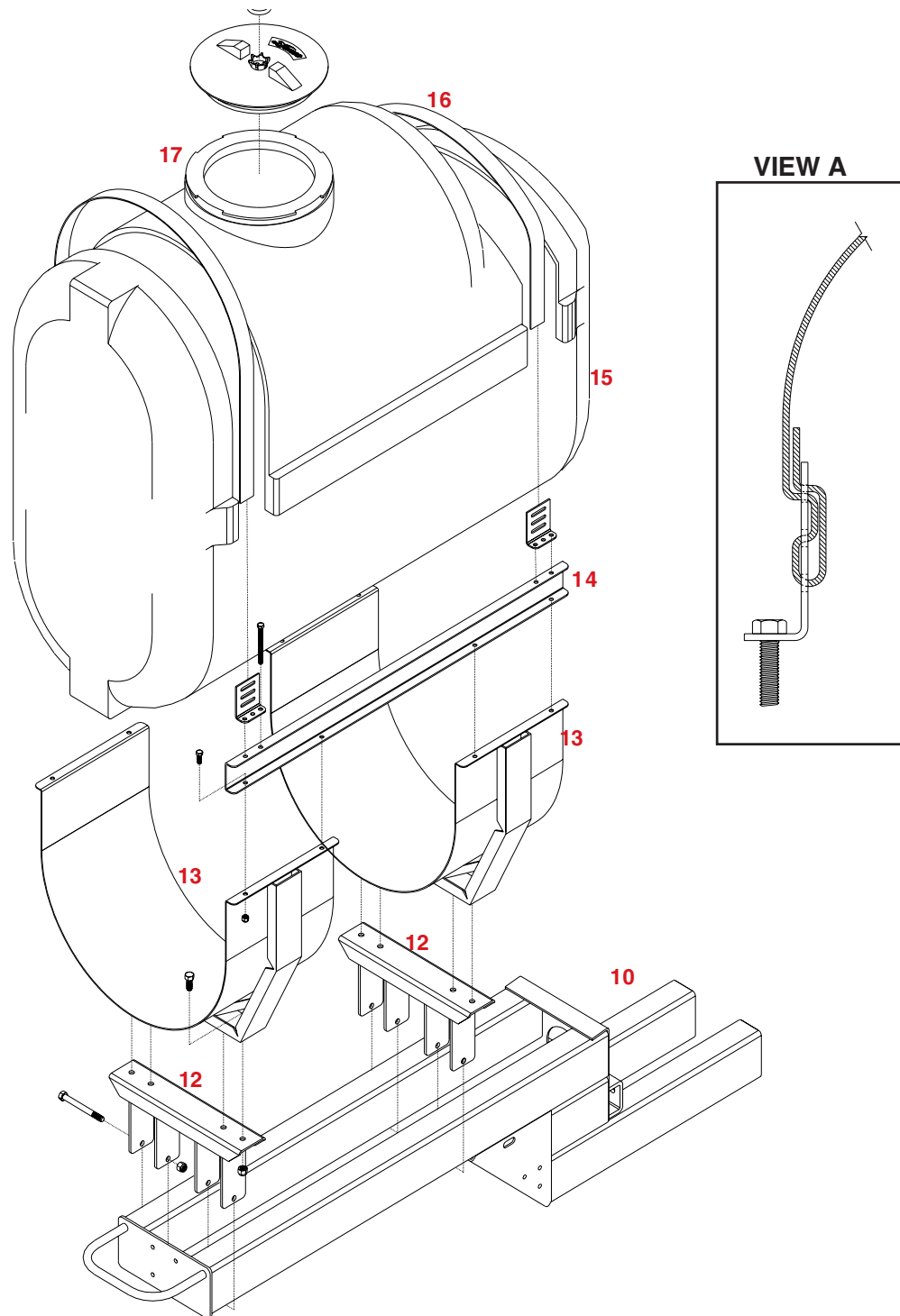

1. Place two saddle mounts (#12) on each of the main frames (#10) as shown. Bolt the saddle (#11) to the saddle mounts using $1/2"$ x $1\ 1/4"$ bolts and locknuts.

NOTE: The two outside saddle mounts may be placed nearer the center of the main frame for smaller tanks.

2. Bolt the tank spreader bar (#14) to the top of the saddles as shown using $3/8"$ x $1"$ bolts and locknuts. Set the tanks (#15) in the saddles as shown. Weave straps through anchors as shown in View A. Secure the tanks with saddle bands (#16 & #17) using $3/8"$ x $5"$ full thread bolts and nuts. Tighten the bolts sufficiently to securely hold the tank in place.

3. Slide the tank/saddle assembly in or out to establish final position on each side, taking care to see that each is positioned an equal distance from the ends of the main frames. Bolt the saddle carriers (#12) to the main frame (#10) using $1/2"$ x $4\ 1/2"$ bolts and locknuts.

NOTE: Make sure that the tanks are not too close to any exhaust manifolds or exhaust pipes.

"QUICK TACH" SIDE MOUNT TANK PARTS BREAKDOWN (for Mechanical Front Wheel Drive Tractors)

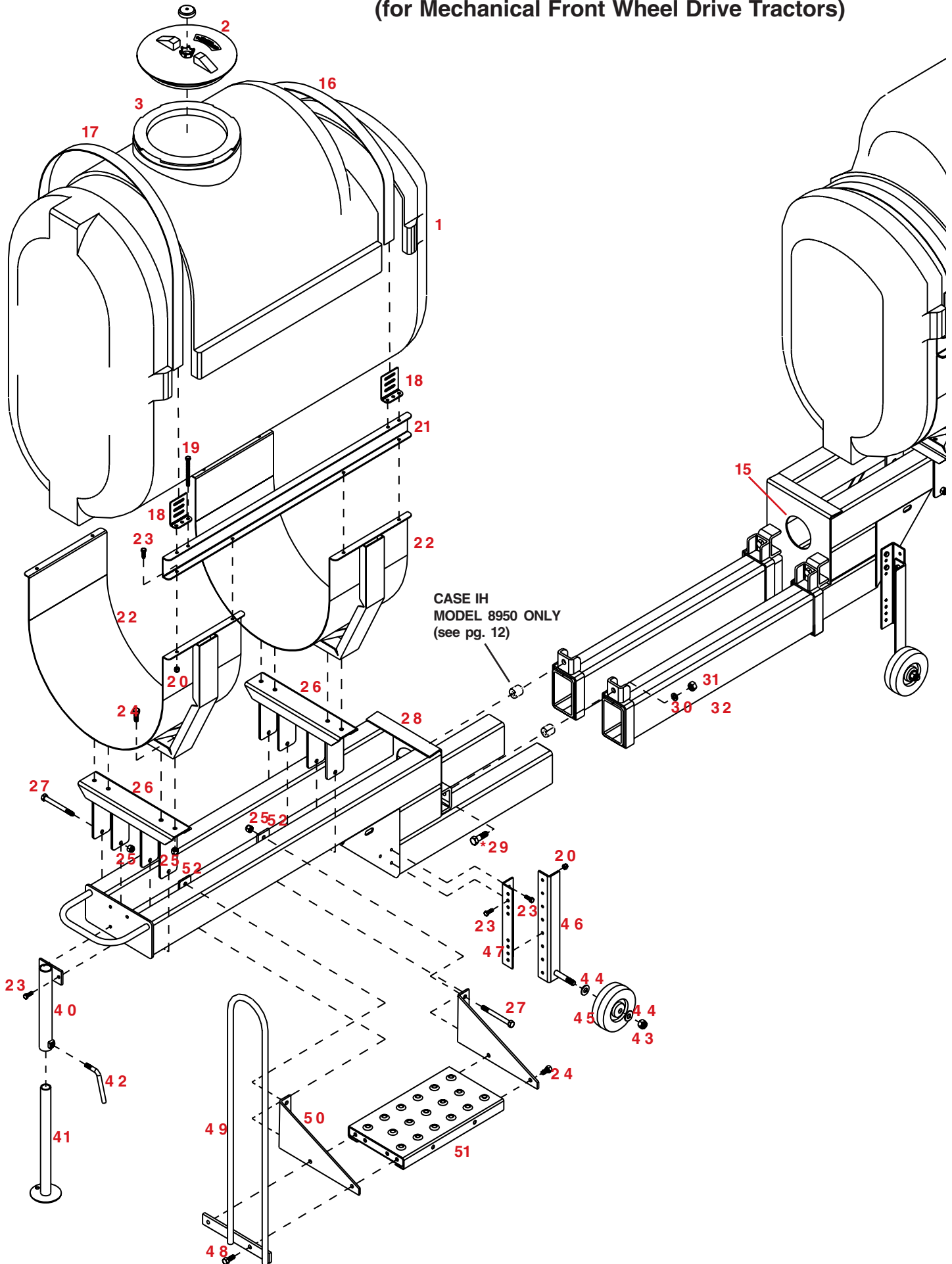

"QUICK TACH" SIDE MOUNT TANK PARTS LIST

REF. NO.	PART NO.	QTY.	DESCRIPTION
1.	P250 24C	2	250 gallon Tank (includes lid, agitation and outlet fittings)
-	P200 24C	2	200 gallon Tank (includes lid, agitation and outlet fittings)
-	P150 24C	2	150 gallon Tank (includes lid, agitation and outlet fittings)
2.	5478R	2	10" diameter lid w/external threads
3.	5479R	-	10" replacement fillwell
-	5079PR	-	Pop Rivets for fillwell
-	D3371PS	2	Double Jet Agitation for poly tank
-	P114PAV	2	1-1/4" Tank Anti-Vortex Outlet Fitting

-	P114PAV	-	1-1/4" Tank Anti-Vortex Outlet Fitting
4.	CP114PAV	1	1-1/4" Anti-Vortex Center Portion
5.	5078V	1	Large "O" Ring Grommet (Viton standard)
6.	N8P	1	Large Nut

-	D3371PS	-	Tank Agitation Assembly (Includes two 5044 1 X)
7.	R1212	1	Agitation Tee Fitting
8.	FC1200	1	1/2" FPT Coupling
9.	M1200	1	1/2" MPT Close Nipple (GFP)
10.	CP012PD	1	Agitation Center Portion
11.	5077V	1	Small "O" Ring Grommet (Viton standard)
12.	N5P	1	Small Nut

13	5044 1	-	Double Jet Agitation Wand Assembly (included w/D3371PS X)
----	---------------	---	------------------------------------------------------------------

15.	05447	2	Grommet
16.	05367	(5)x2	1-3/4" Short Polyester Tank Band (56") (order per ft.)
17.	05367	(7)x2	1-3/4" Long Polyester Tank Band (74") (order per ft.)
18.	05785-95	8	Small Strap Anchor
19.	01885	16	3/8"-16 UNC x 5" Full Thread Bolt
20.	02592	32	3/8"-16 UNC Nylon Insert Locknut
21.	01701-35	4	50-1/2" Long Spreader Bar for 250 gallon tank
-	01700-35	4	44" Long Spreader Bar for 200 gallon tank
-	01699-35	4	41" Long Spreader Bar for 150 gallon tank
22.	01678-35	4	24" Saddle
23.	00907	16	3/8"-16 UNC x 1" Hex Head Bolt (gr. 5)
24.	00967	8	1/2"-13 UNC x 1-1/4" Hex Head Bolt (gr. 5)
25.	02178	16	1/2"-13 UNC Nylon Insert Locknut
26.	01758-35	4	Saddle Mount
27.	01338	8	1/2"-13 UNC x 4-1/2" Hex Head Bolt (gr. 5)
28.	05100-35	2	Side Mount Frame for MFD
29.	00290	4	5/8"-18 UNC x 2" Hex Head Bolt (gr. 5)
-	04215	4	5/8"-18 UNC x 3" Hex Head Bolt (gr. 5) (Case IH model 8950only)
31.	02587	4	5/8"-18 UNC Nylon Insert Locknut
32.	04850-35	2	60" Long Undercarriage Tubes

20.	QTWL	1	Optional Wheels and Jackstand - High Clearance 9470001
23.	00061	20	3/8"-16 UNC Hex Nut
23.	00907	20	3/8"-16 UNC x 1 Hex Head Bolt (gr. 5)
40.	01757-35	2	Top Jackstand Tube
41.	01756-35	2	Bottom Jackstand Tube - (High Clearance #03906)
42.	00161-95	2	Lock Handle
43.	02587	4	5/8"-11 UNC Nylon Insert Locknut
44.	00496	8	5/8" Narrow Rim Machine Washer
45.	04445	4	6" x 2" Soft Tread Rubber Wheel
46.	01764-35	2	Right Lower Axle Bracket (shown)
-	01770-35	2	Left Lower Axle Bracket (not shown)
47.	01763-35	4	Upper Wheel Bracket - (High Clearance #03905)
53.	00060	20	3/8" Lockwashers

24.	QTST	1	Optional Step Platform (includes items 24-52 below)
24.	04795	2	1/2"-13 UNC x 1" Hex Head Bolt (gr. 5)
25.	02178	8	1/2"-13 UNC Nylon Insert Locknut
27.	01338	4	1/2"-13 UNC x 4-1/2" Hex Head Bolt (gr. 5)
48.	00967	2	1/2"-13 UNC x 1-1/4" Hex Head Bolt (gr. 5)
49.	01767-35	1	Handrail
50.	01765-35	2	Platform Mounting Bracket
51.	01768-35	1	Step Platform
52.	01766-35	4	Back-Up Plate

Please order replacement parts by **PART NUMBER** and **DESCRIPTION**.

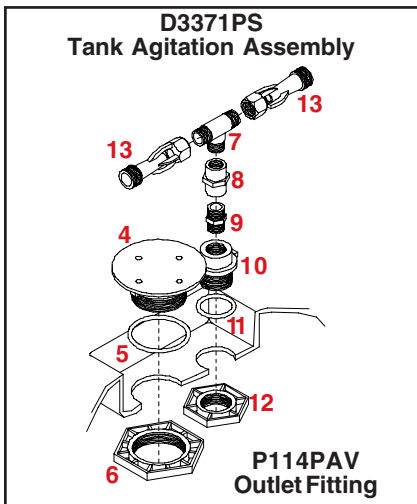

INSTALLING THE OPTIONAL JACK AND WHEELS (QTWL) MOUNTING THE OPTIONAL STEP PLATFORM (QTST)

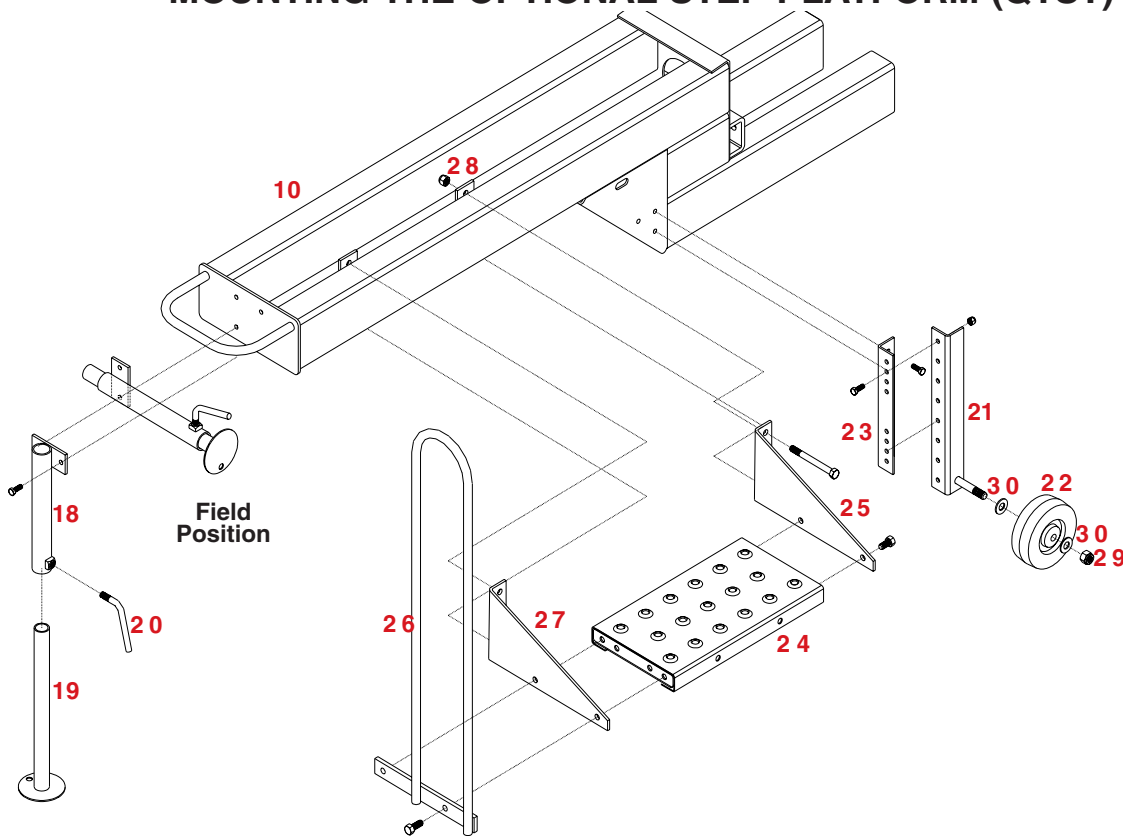

MOUNTING THE JACK & WHEELS

1. Bolt the top half of the jack (#18) to the front set of holes in the end plate of the main frame (#10) using 3/8" x 1" bolts and locknuts. Slide the bottom half of the jack (#19) into the top half and secure with 1/2" lock handle (#20). When jack is needed, remove the top bolt, turn the jack to a vertical position, place bolt in rear hole and secure with the lock-washer and nut. Loosen locking handle until bottom part of the jack rests on ground and tighten locking handle again.

2. Place a 5/8" machine washer (#30) over the welded-in bolt located on the bottom of the axle bracket (#21). Slide one wheel (#22) onto the axle, place another 5/8" machine washer over the axle and secure with a 5/8" locknut (#29).

NOTE: Axle brackets (#21) are shipped with two *lefts* and two *rights*. A *right* axle bracket is shown in the illustration above.

3. Bolt the upper wheel bracket (#23) to the mount welded on the side of the main frame (#10) as shown using 3/8" x 1" bolts.

NOTE: For initial adjustment, bolt upper wheel bracket (#23) to the mount in a vertical position. Bolt the axle bracket (#21) to the upper wheel bracket as shown using 3/8" x 1" bolts so that the wheel is an inch or two above the ground.

NOTE: When wheels are needed, remove the bolt, turn the bracket to a vertical position, replace the bolt and tighten.

NOTE: In some cases the wheel kit unit may need to be removed.

MOUNTING THE STEP PLATFORM

1. Bolt the platform (#24) to the right hand platform bracket (#25) using 1/2" x 1" bolts and locknuts.

2. Bolt the hand rail (#26) and the left hand platform bracket (#27) to the left side of the platform using 1/2" x 1-1/4" bolts and locknuts.

3. Mount the assembled platform to the retaining plates (#28) using 1/2" x 4-1/2" bolts and locknuts. The platform may be placed in the front or rear of the main frame.



Jackstand and Wheels make empty storage easy.

Notes:

Notes:

EQUIPMENT CHECKLIST:

Downtime caused by field breakdowns is costly and time consuming. Many breakdowns can be eliminated by periodic equipment maintenance. By spending time reviewing this checklist before seasonal spraying application time and following proper after-season care, you can save time and money later.



WARNING: To Prevent Serious Injury Or Death

- Keep hands, feet, and loose clothing away from rotating parts.
- Wear protective clothing recommended by your chemical and fertilizer manufacturer when working with chemicals.

Check Before Going To The Field :

- 1. HOSES**
Check all hoses for worn or soft spots. Be sure all hose clamps are tightened and hoses are not kinked or pinched. Check for leakage in any lines.
- 2. TANK**
Inspect fitting and grommets to insure they are in good condition.
- 3. CONTROLS**
Check for leakage, plugging, or wear on all valves, fittings, etc. Clean off any build up of foreign material.
- 4. PUMP**
Check to be sure pump turns freely.
- 5. FRAME**
Be sure all bolts are tightened.
- 6. REPLACEMENT PARTS**
Replace all worn or damaged parts.

After Season Care:

NOTE: It is important to wear proper safety equipment when cleaning the sprayer. See your chemical or fertilizer package for this information.

1. After spraying chemicals, run water mixed with cleaners through tank, pump and all hose hookups. If wettable powder dries out in the system, it is very difficult to put back into suspension and can cause malfunction, damage or injury.
2. When cleaned, tank should have all openings closed or covered to keep dirt from entering.
3. Pump should be flushed with soluble oil and pump ports plugged to keep out moisture and air.
4. Disassemble tips and rinse with water or cleaning solution. (Appropriate for chemical sprayed). Never use wire or hard object that could distort opening.
5. Dispose of all unused chemicals or solutions in a proper and ecologically sound manner.
6. Water rinse and dry tips before storing.



DETHMERS MFG. COMPANY
P.O. BOX 189
4010 320th St., BOYDEN, IA. 51234
PH: (712) 725-2311 FAX: (712) 725-2380
TOLL FREE: 1-800-54DEMCO (1-800-543-3626)
www.demco-products.com

NOTE: DETHMERS MANUFACTURING COMPANY does not and will not make any recommendations concerning application of various chemicals or solutions. These recommendations relate to either amount or procedure of materials applied. If you have any questions regarding application of certain chemicals or solutions, contact your chemical supplier and follow chemical manufacturer recommendations.