

# Croft DA10 ACTUATOR PARTS BREAKDOWN (8102822)

07-02  
BH20018, Rev 1

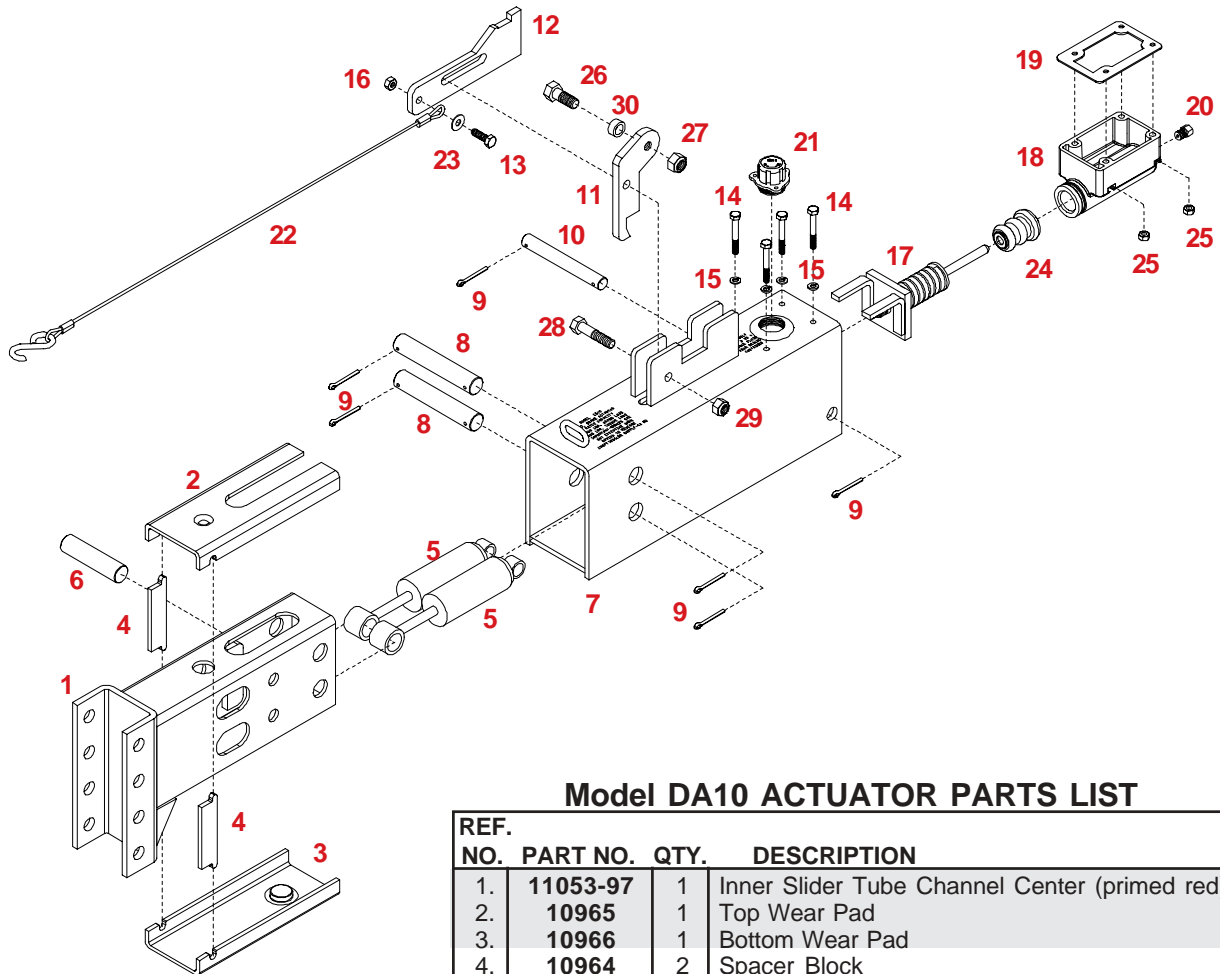

## Model DA10 ACTUATOR PARTS LIST

REF. NO.	PART NO.	QTY.	DESCRIPTION
1.	11053-97	1	Inner Slider Tube Channel Center (primed red)
2.	10965	1	Top Wear Pad
3.	10966	1	Bottom Wear Pad
4.	10964	2	Spacer Block
5.	SB12426	2	Damper Shock
6.	05973-95	1	Front Shock Pin (zinc plated)
7.	11110-97	1	Outer Case (primed red)
8.	05986-95	2	Connecting Pin (zinc plated)
9.	02363	6	5/32" x 1-1/4" Cotter Pin
10.	05974-95	1	Rear Shock Pin (zinc plated)
11.	07130-95	1	Emergency Lever (zinc plated)
12.	07131-95	1	Slide Plate (zinc plated)
13.	02990	1	5/16"-18 UNC x 1" Hex Head Bolt Gr.5
14.	00618	4	1/4"-20 UNC x 2" Hex Head Bolt Gr.5
15.	00057	4	1/4" Lock Washer
16.	05962	1	5/16"-18 UNC Center Punch Lock Nut
17.	05989	1	Push Rod Assembly
18.	5650	1	Master Cylinder (includes #is 14,15,19, and 25)
19.	09153	-	Replacement Master Cyl. Gasket ONLY
20.	SB12098	1	1/8" pipe - 3/16" Fitting w/ Orifice
21.	03876	1	Master Cylinder Cap w/ Diaphragm and O-Ring
-	05849	-	O-Ring (replacement)
22.	07210	1	3/32" Cable with hook
-	SB10555	-	Replacement S-hook ONLY
23.	00004	1	5/16" Flat Washer
24.	05687	1	Master Cyl. Protective Boot
25.	00062	4	1/4"-20 UNC Hex Nut
26.	01254	1	1/2" -13 UNC x 1-1/2" Hex Head Bolt Gr. 5
27.	00173	1	1/2" -13 UNC Center Punch Lock Nut
28.	00203	1	7/16" -14 UNC x 1-3/4" Hex Head Bolt Gr. 5
29.	03527	1	7/16" -14 UNC Center Punch Lock Nut
30.	02491-95	1	3/4" O.D. x 1/2" I.D. x 1/2" long Bushing
-	5398	-	Master Cylinder Repair Kit w/ gasket

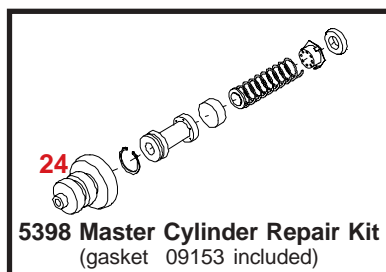

Please order replacement parts by PART NO. and DESCRIPTION.